

男子団体

第一試合場

第二試合場

第三試合場

第四試合場

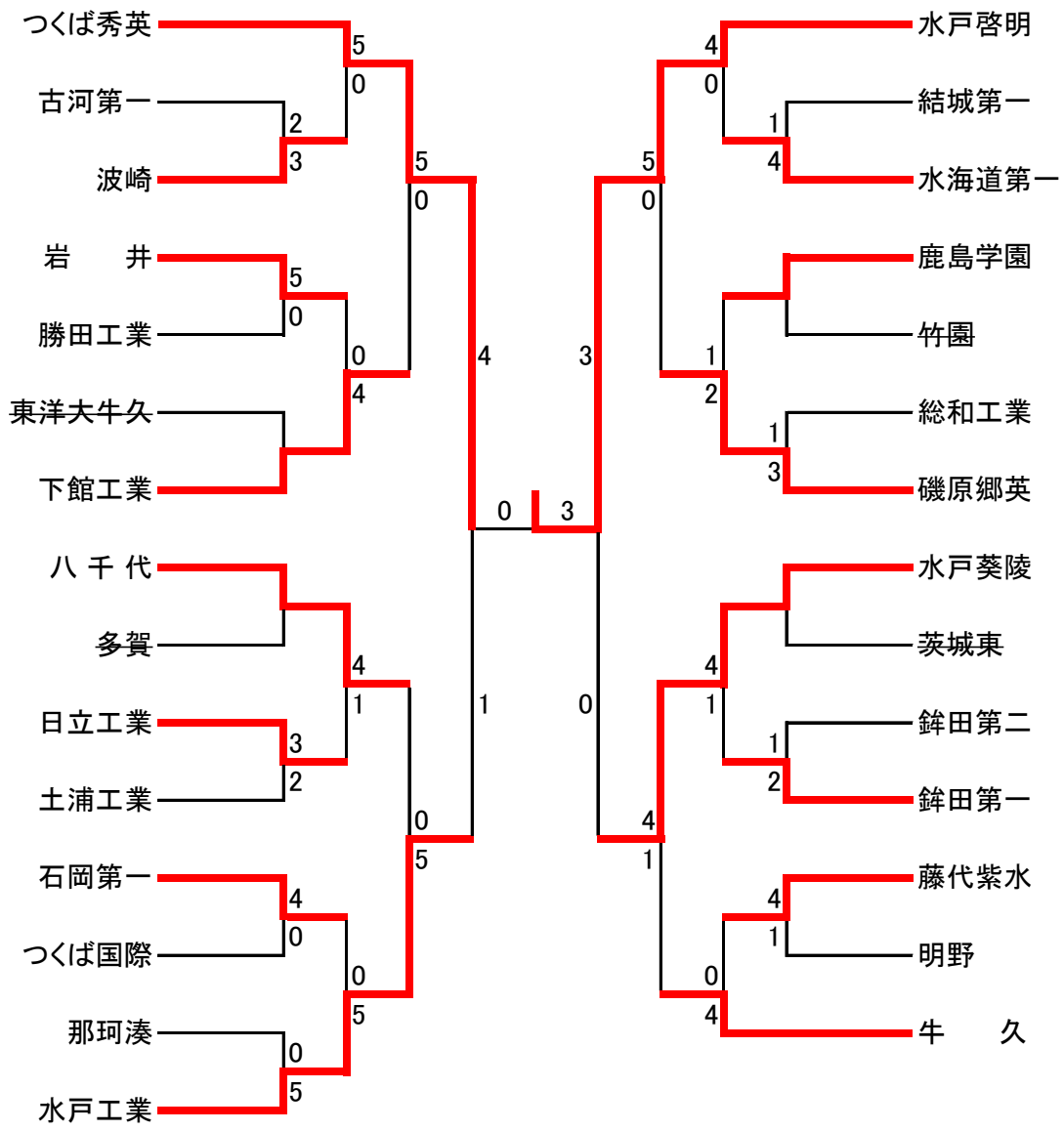

3位決定戦

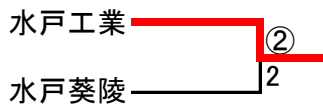

男子60kg級

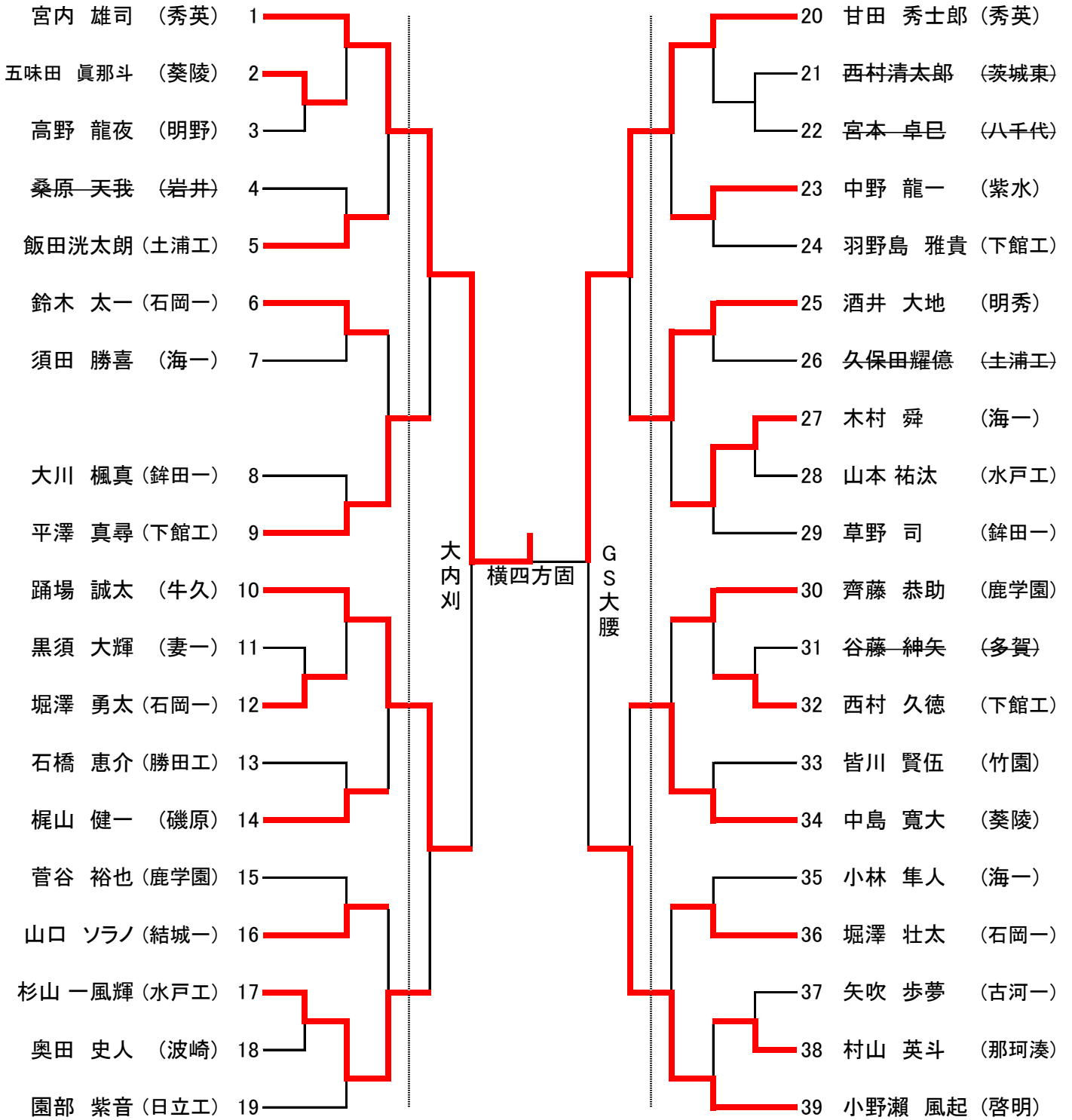

男子66kg級

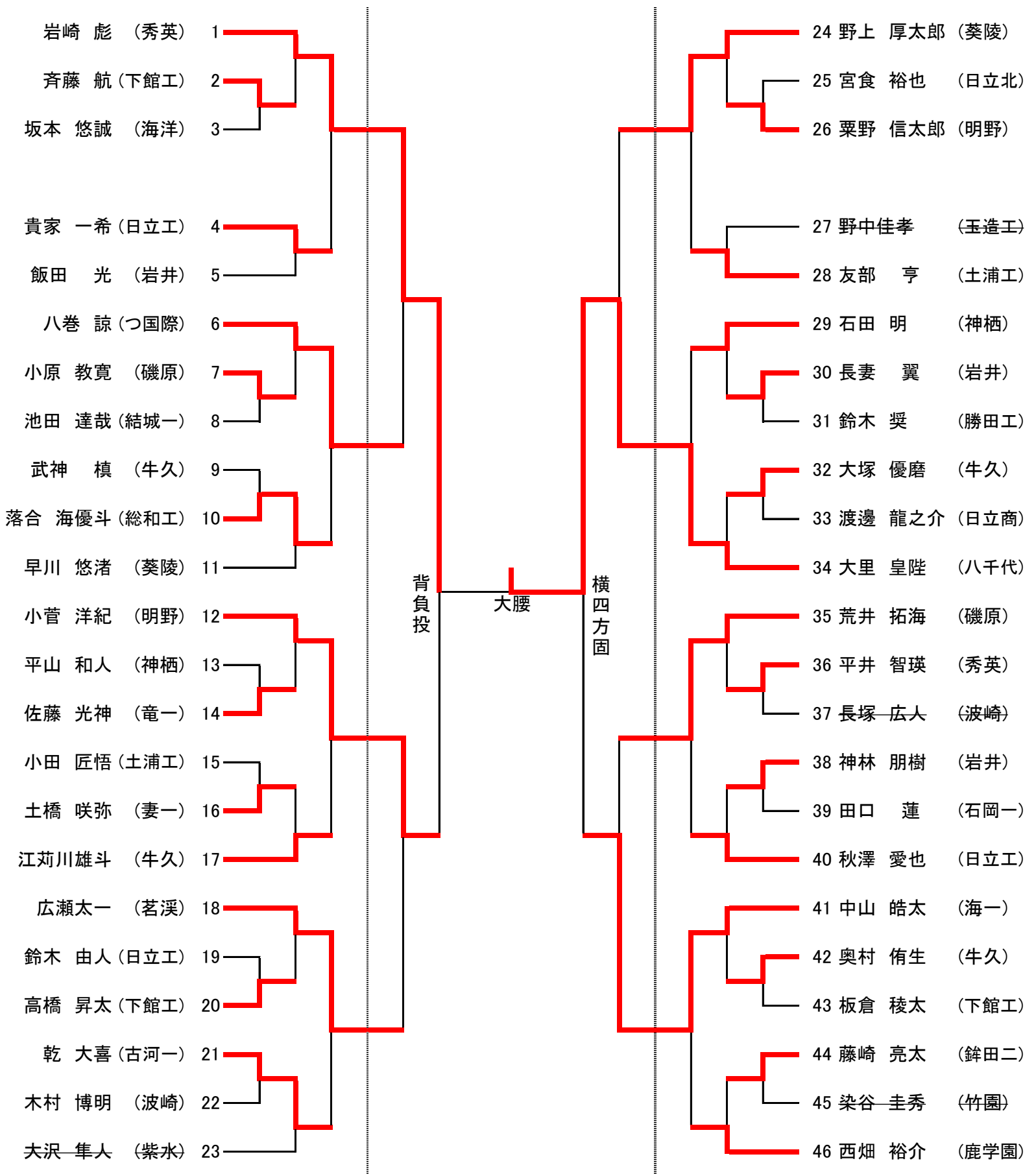

男子73kg級

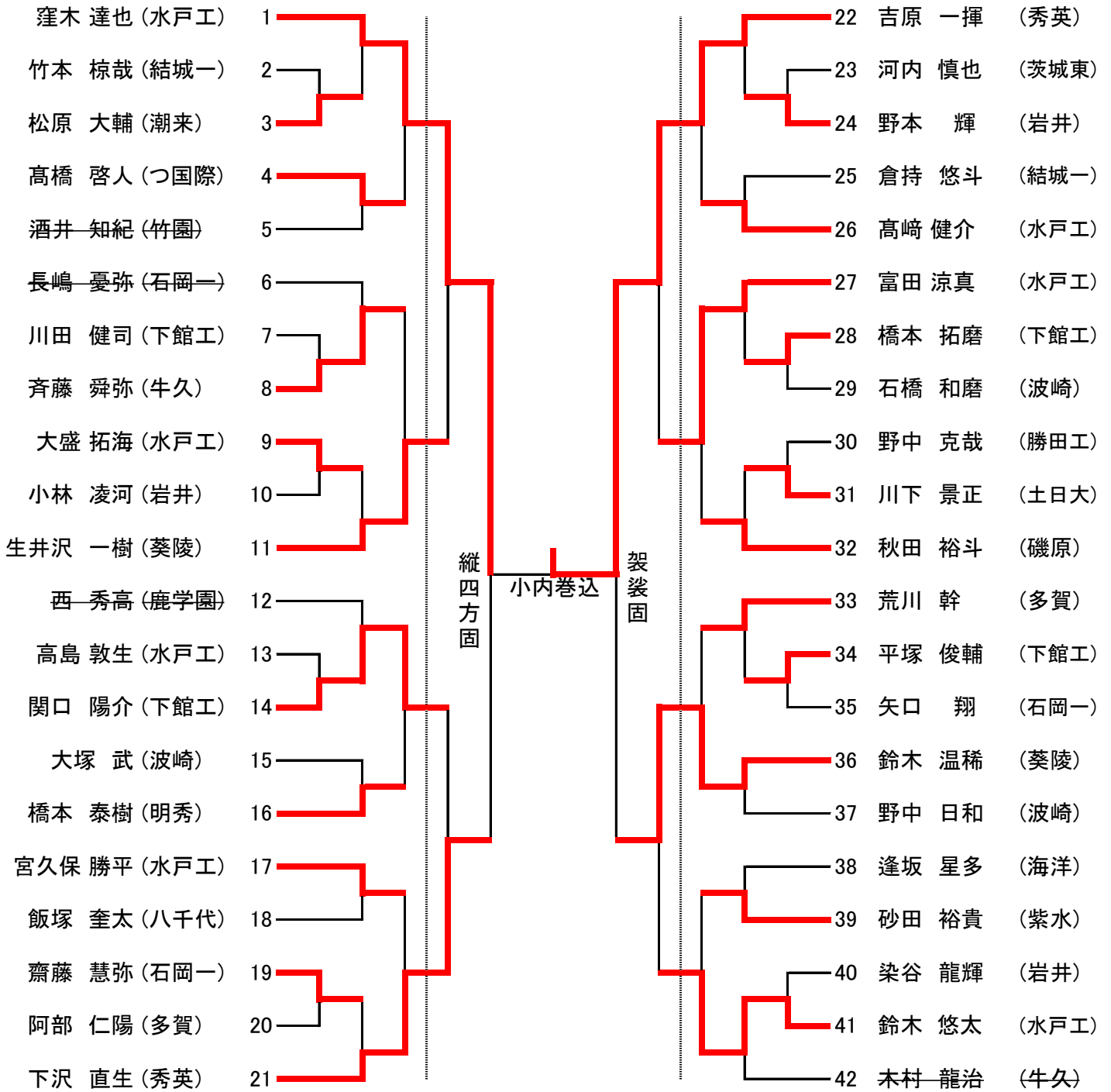

男子81kg級

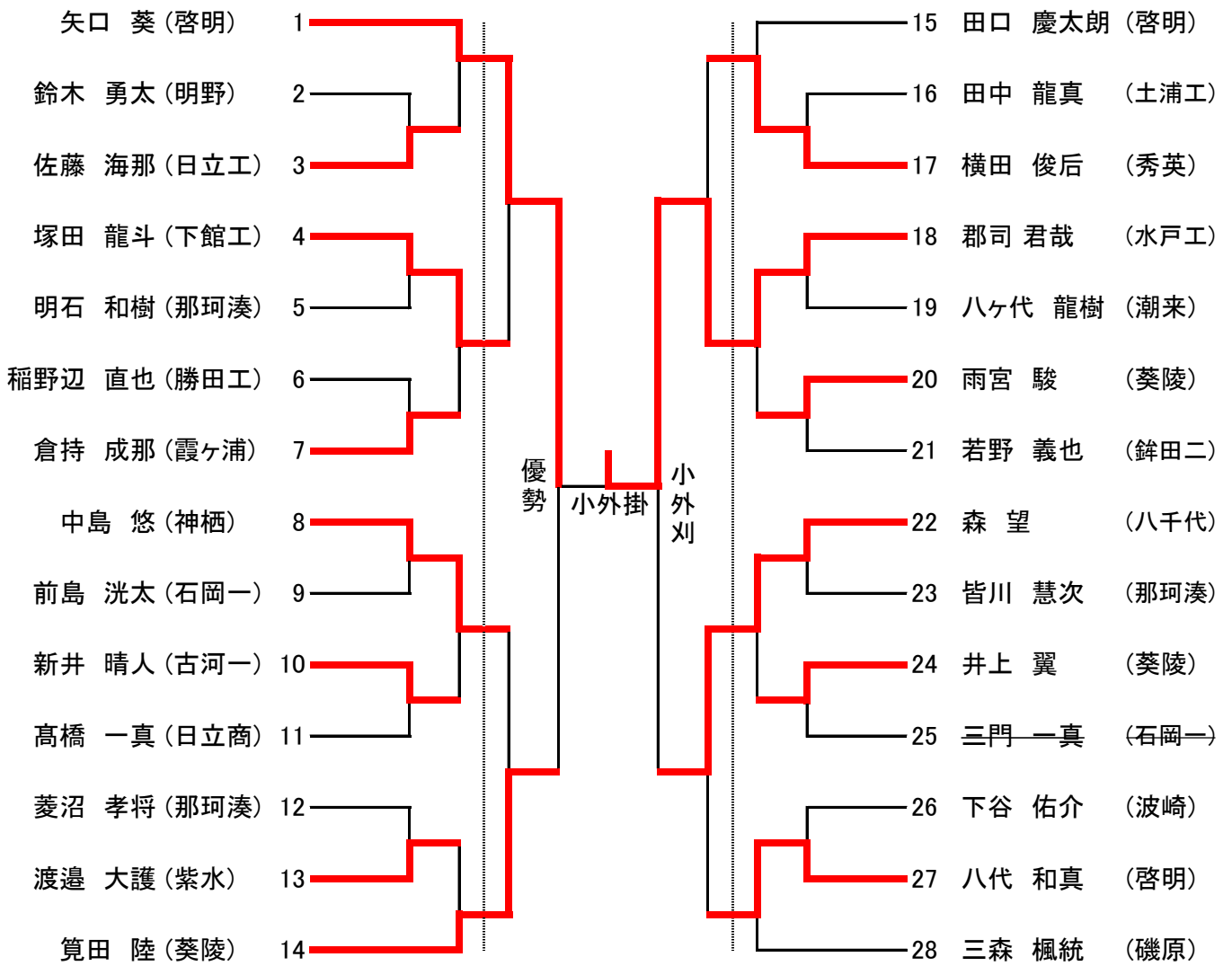

男子90kg級

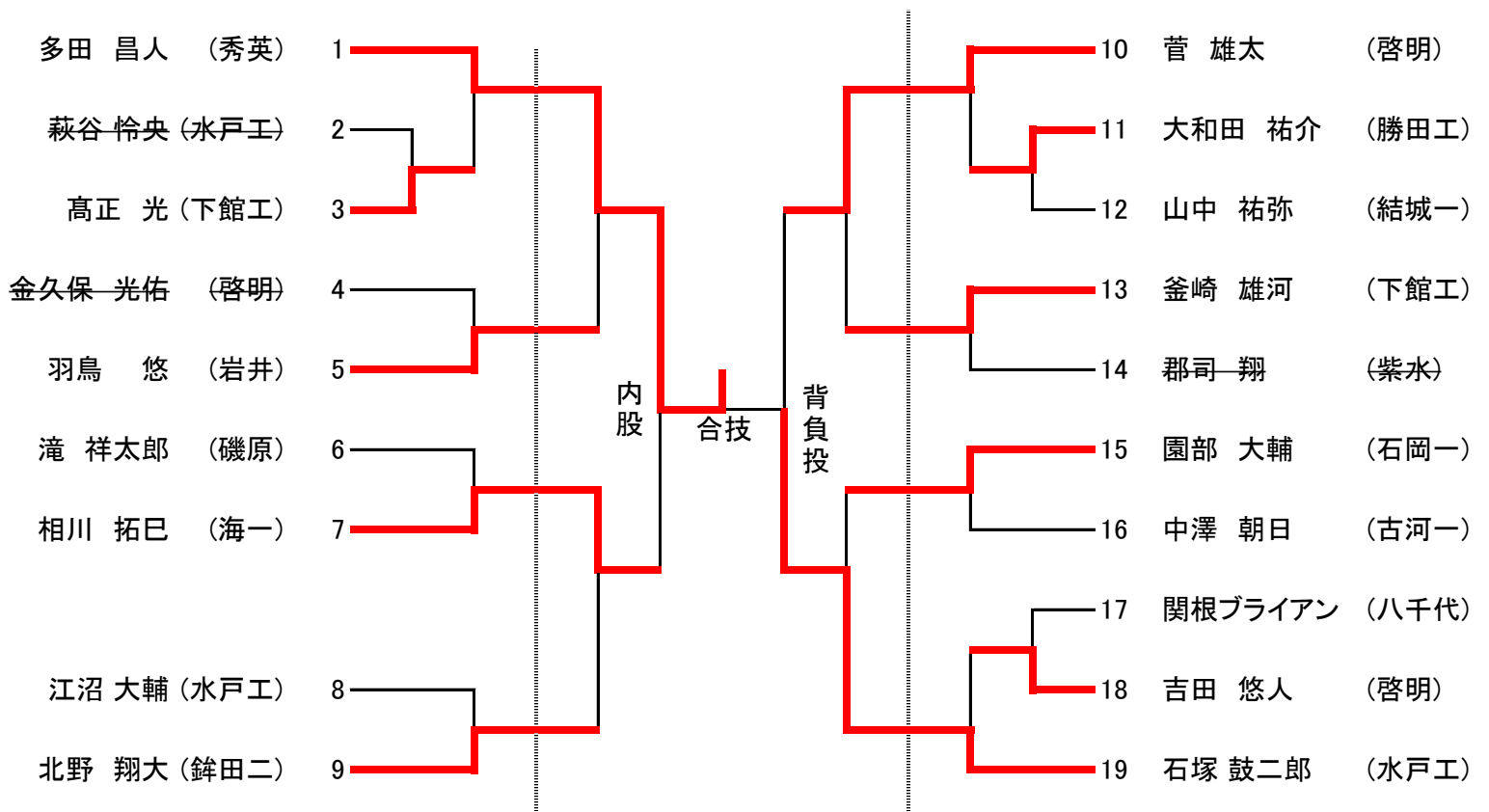

男子100kg級

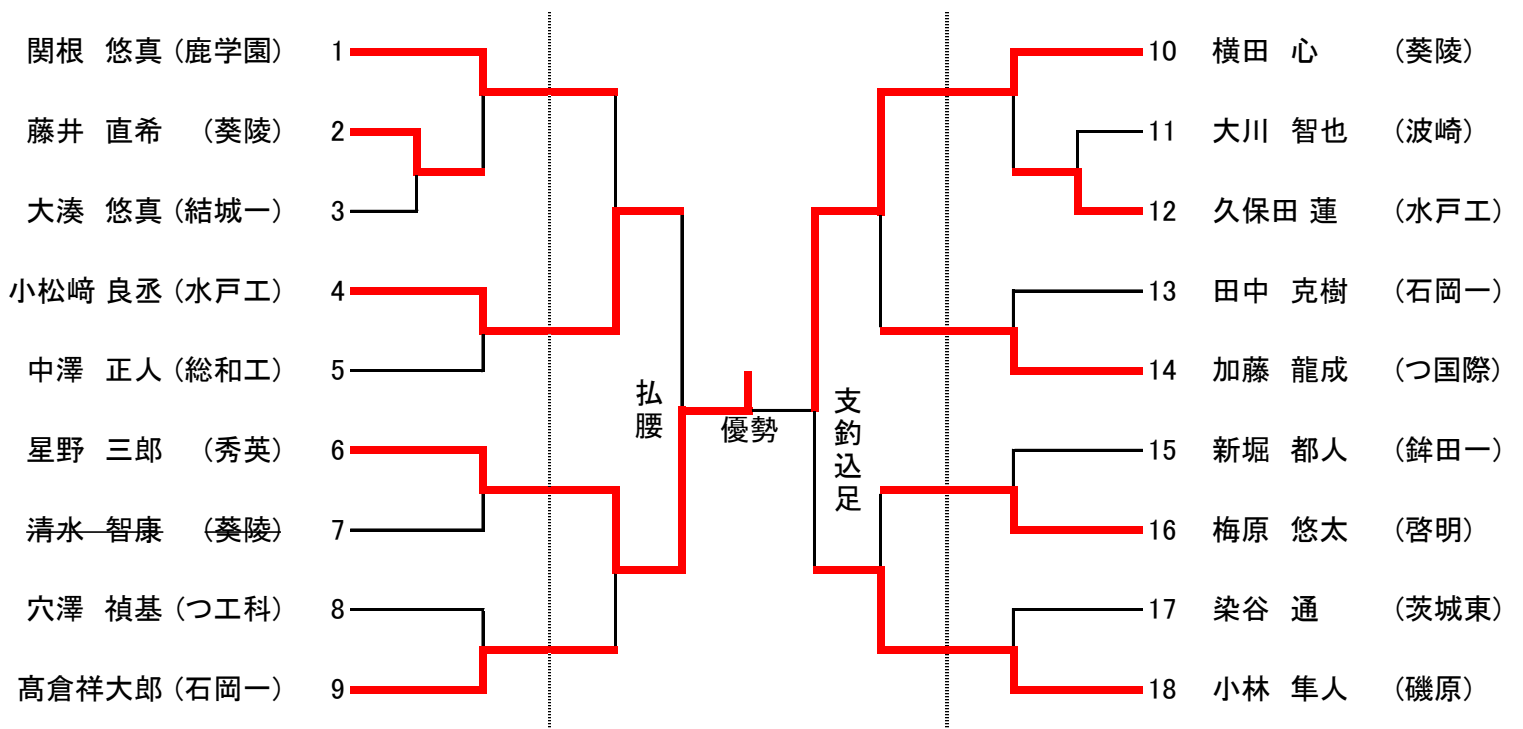

# 男子100kg超級

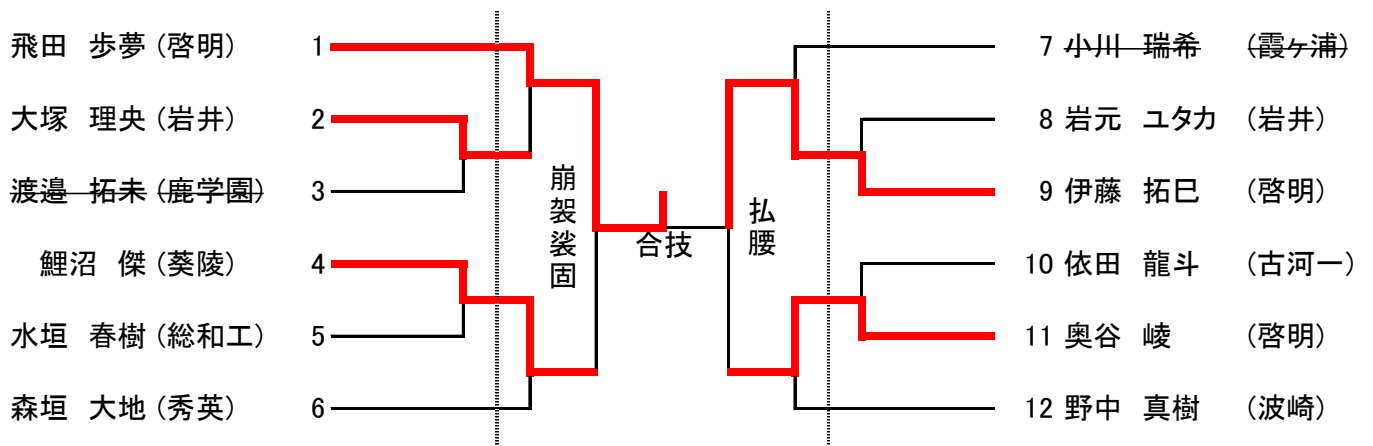



女子団体

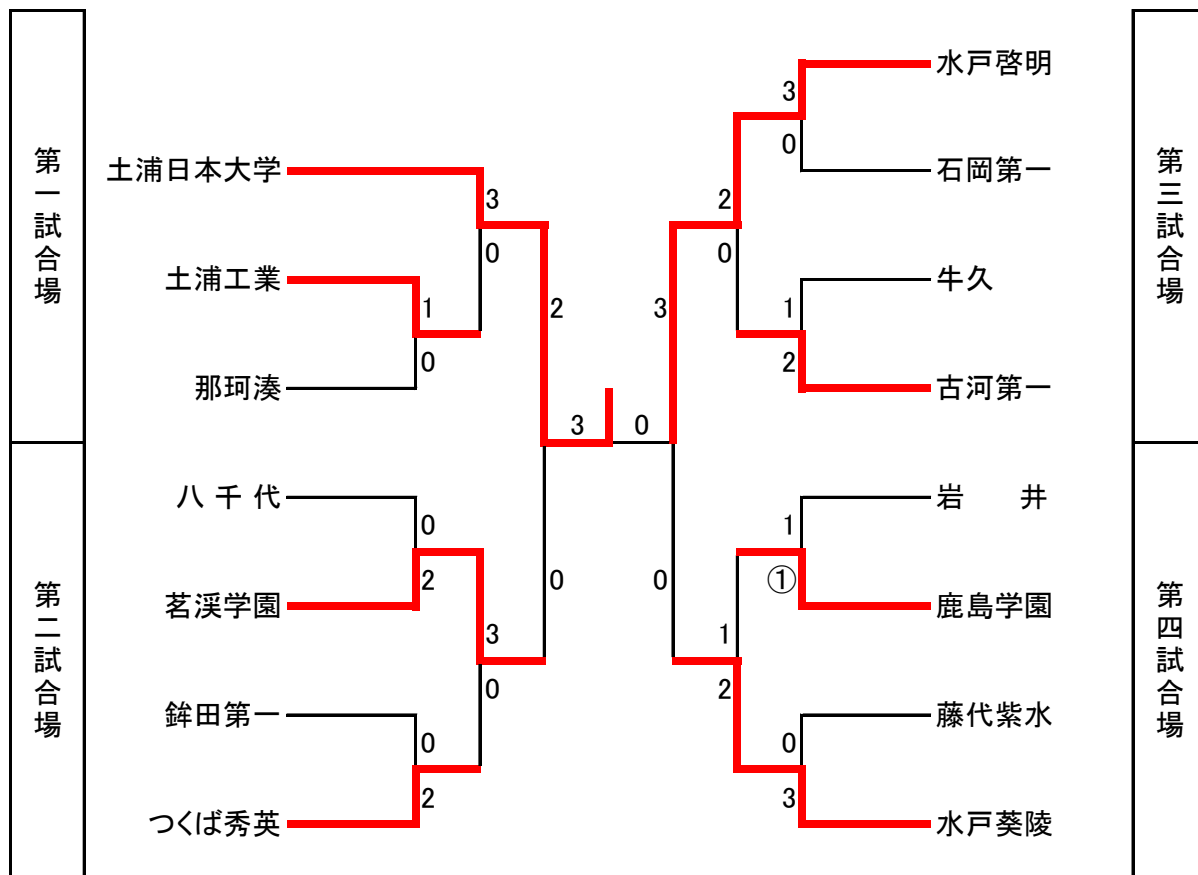

3位決定戦

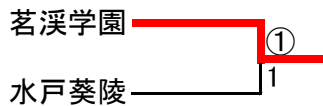

女子48kg級

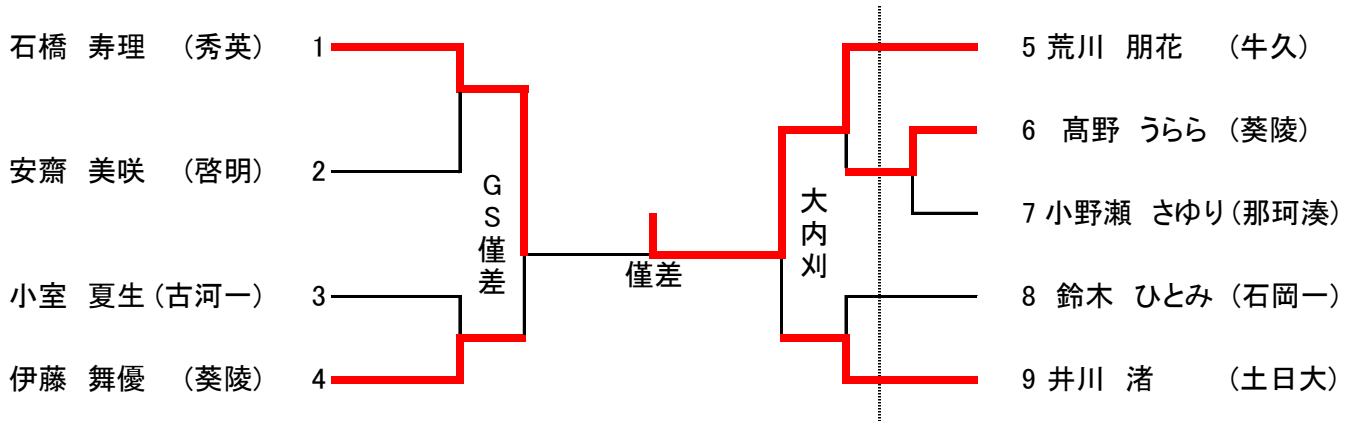

女子52kg級

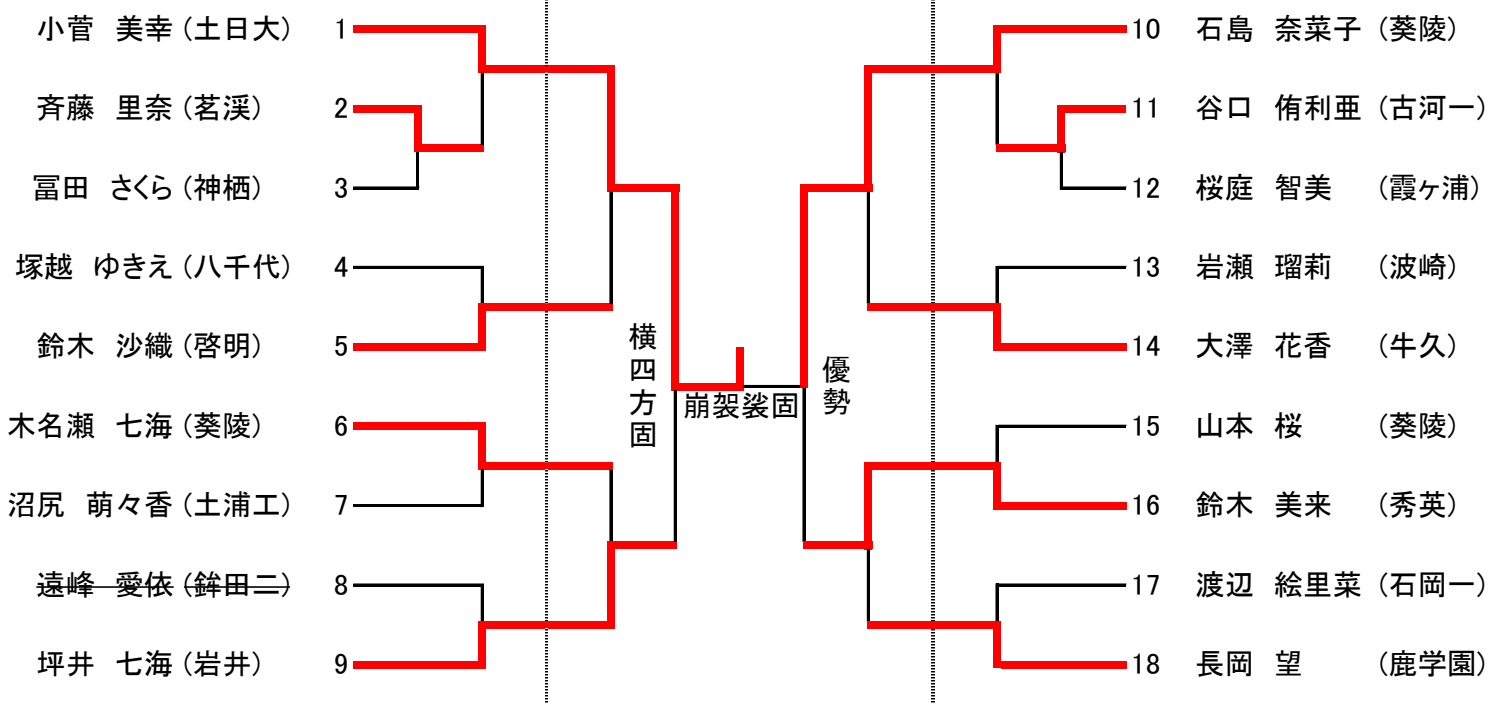

女子57kg級

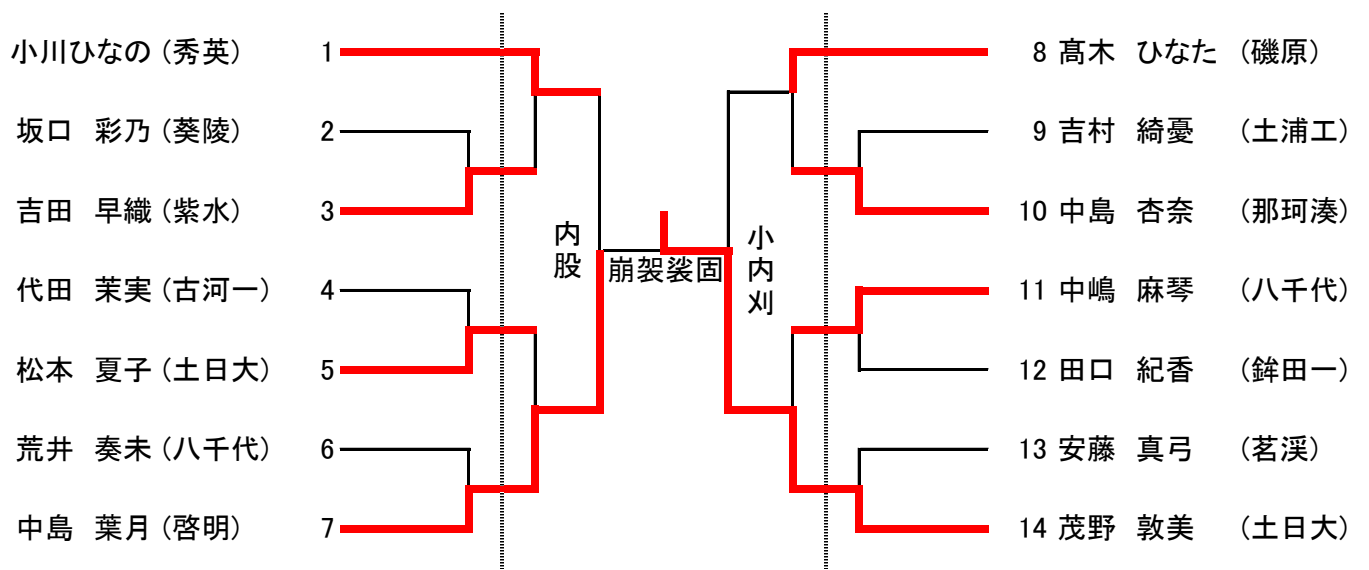

女子63kg級

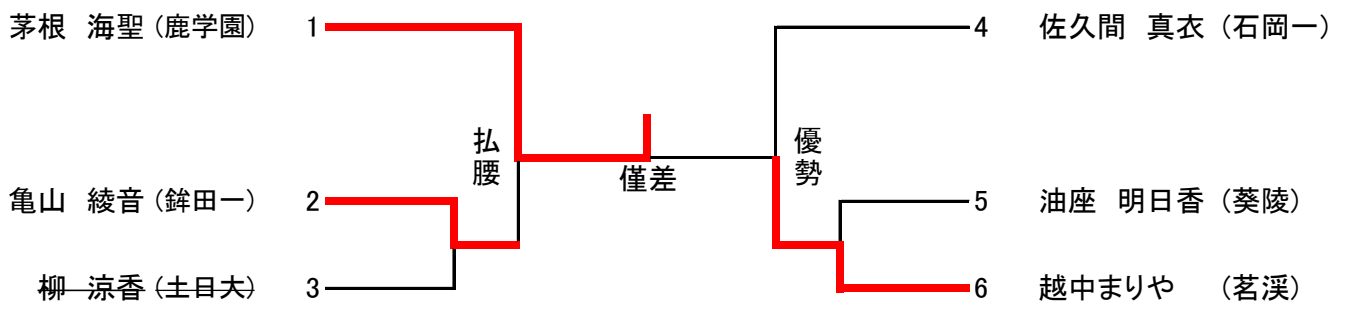

女子70kg級

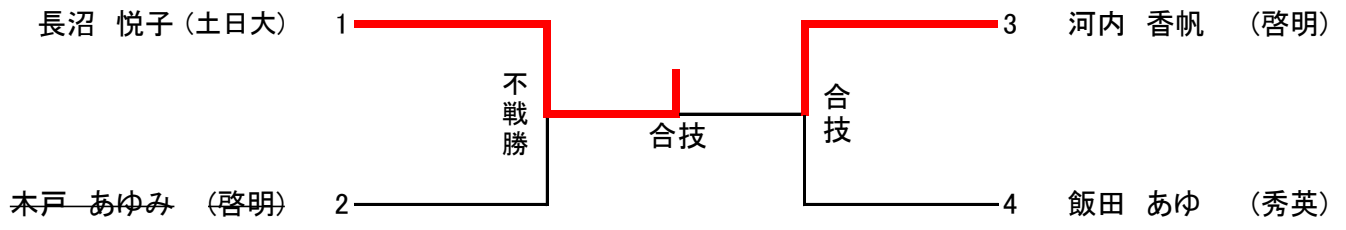

女子78kg級

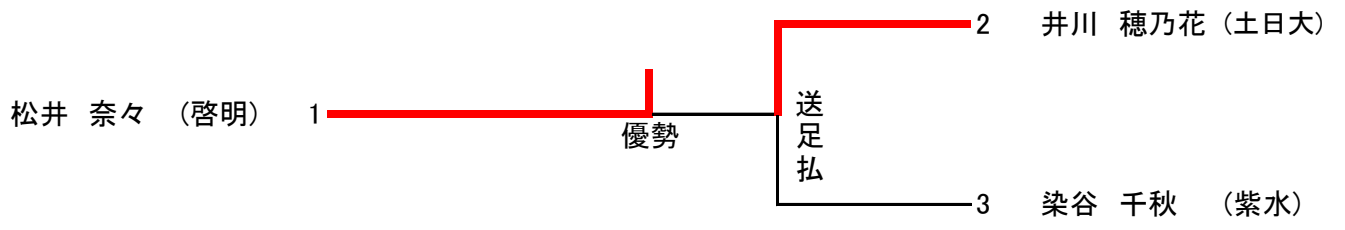

女子78kg超級

