

男子団体戦

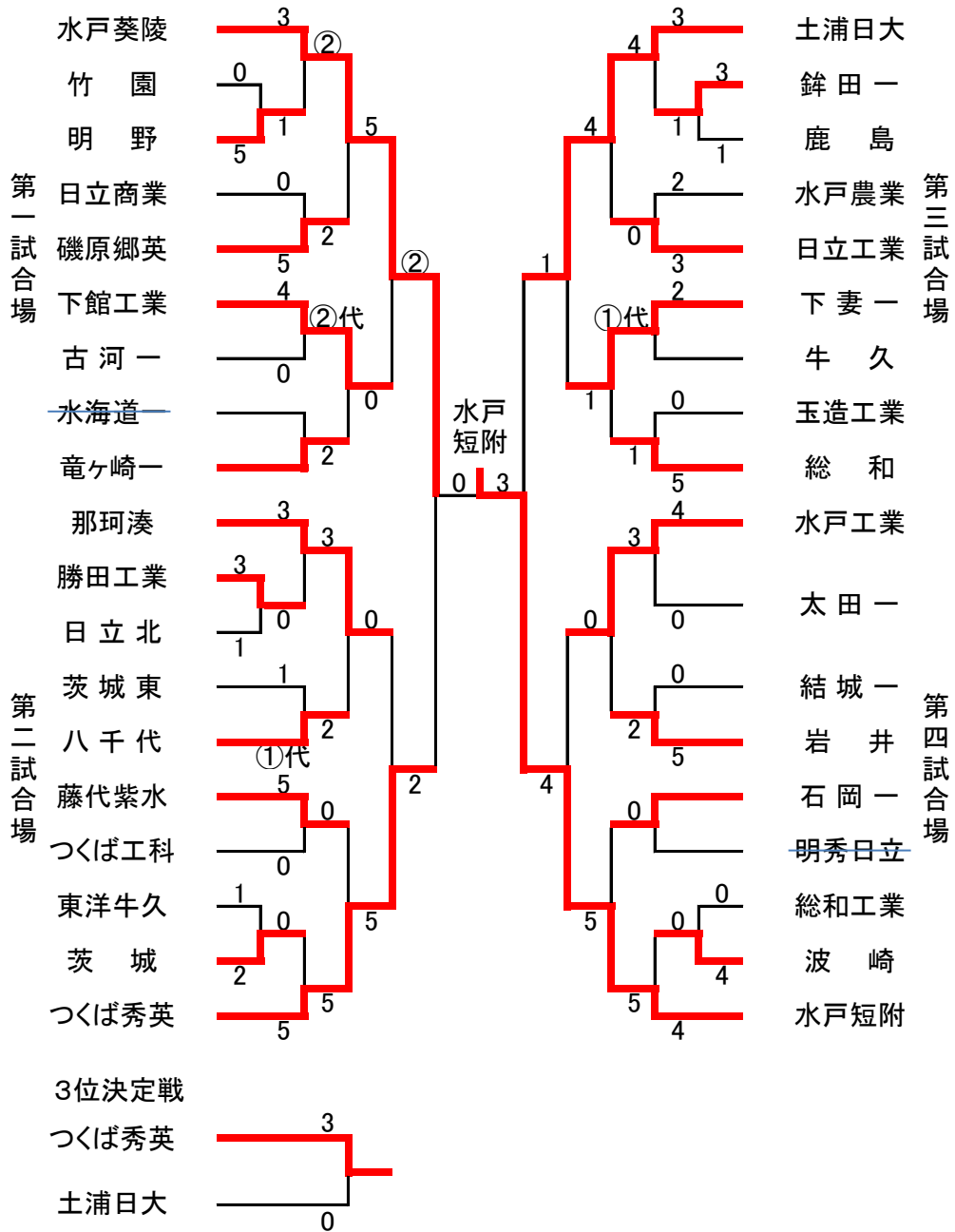

男子個人60kg級

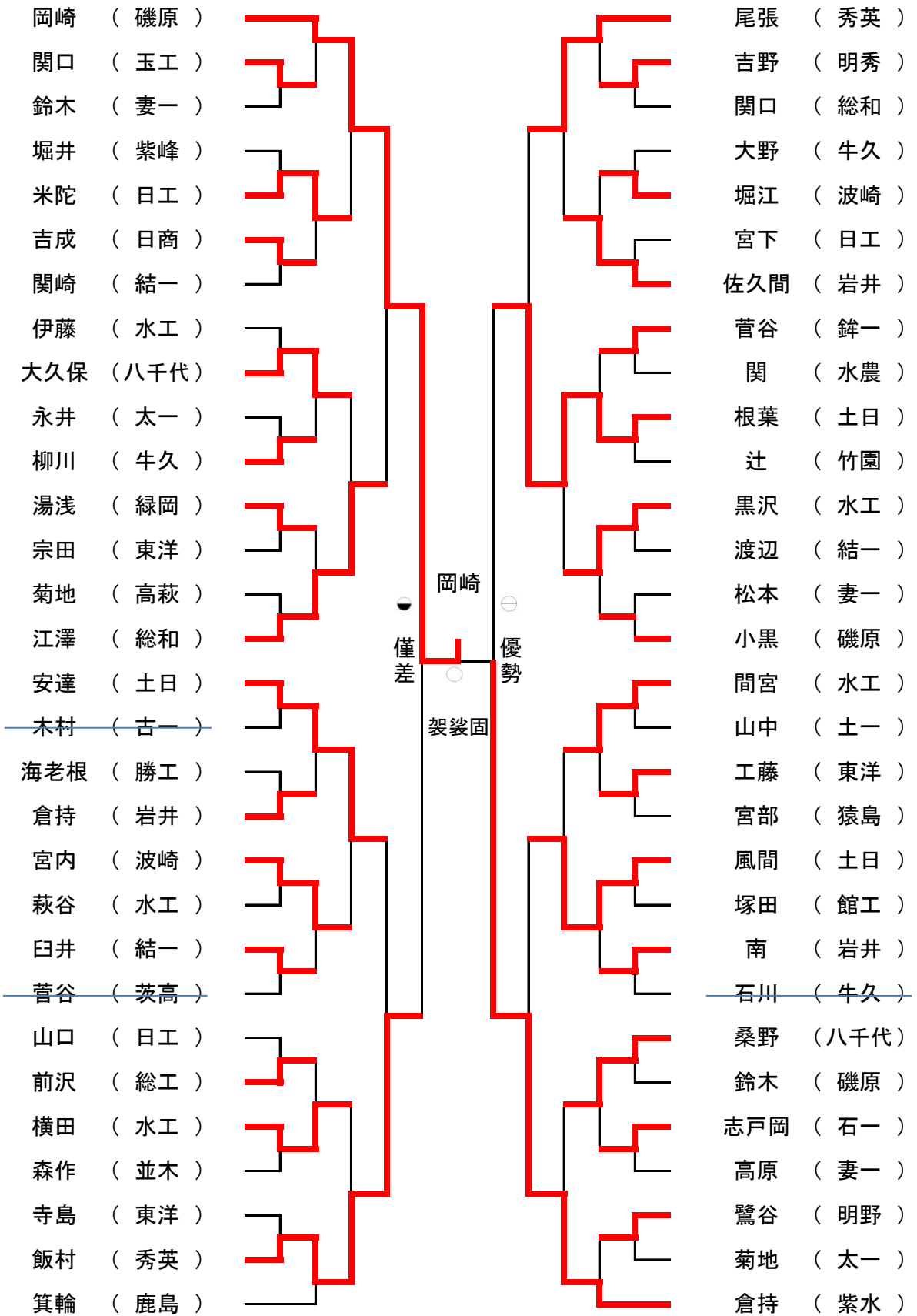

男子個人66kg級

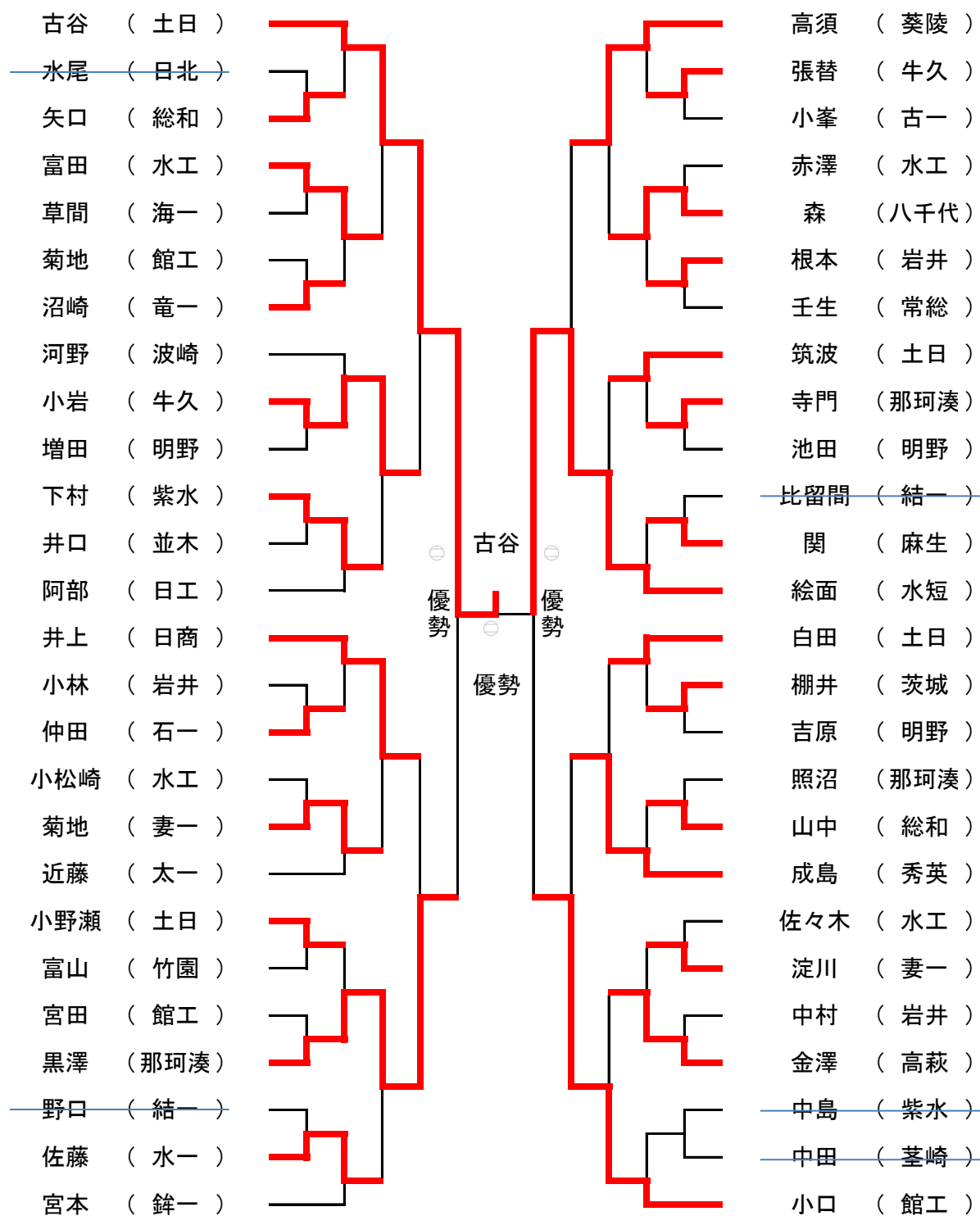

男子個人73kg級①

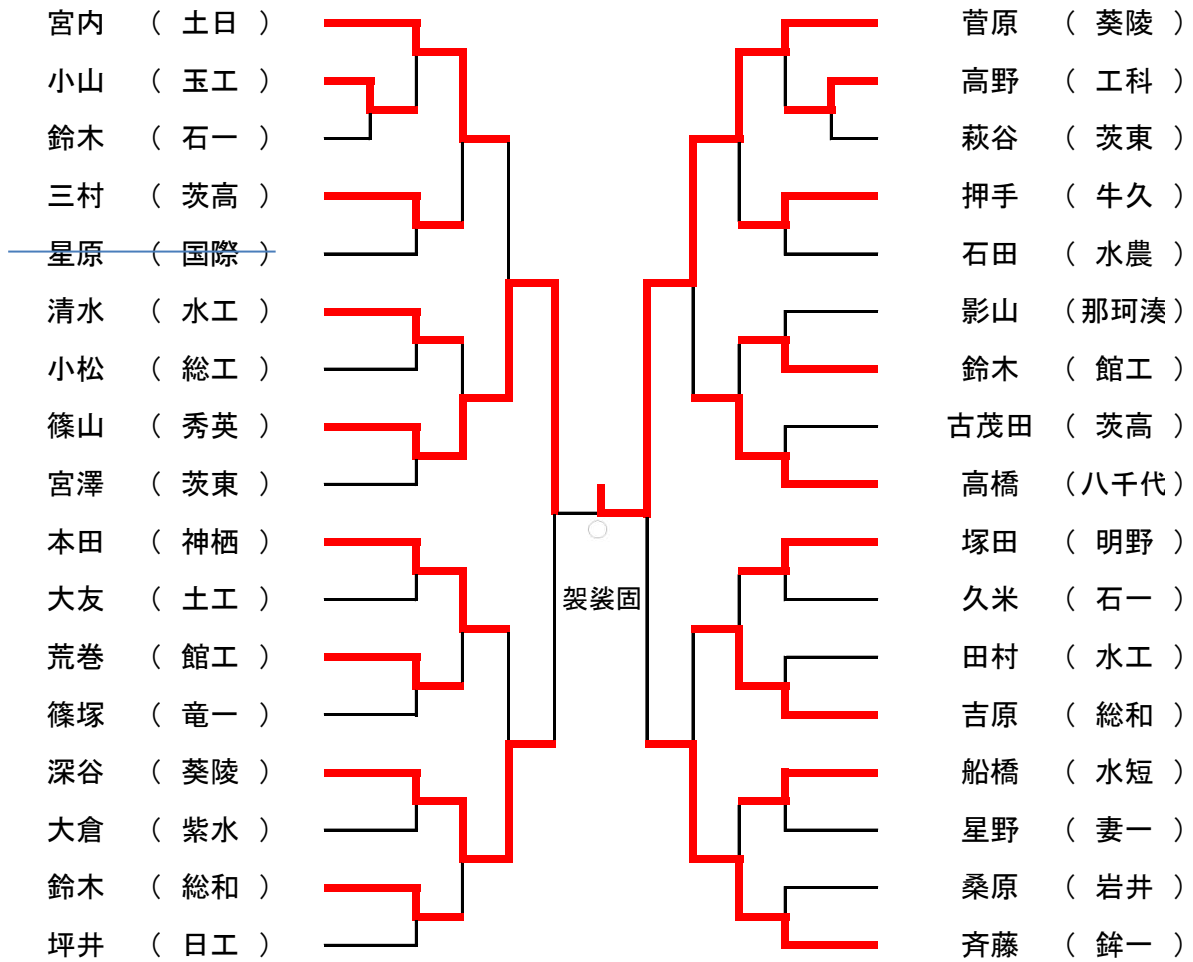

決勝戦



男子個人73kg級②

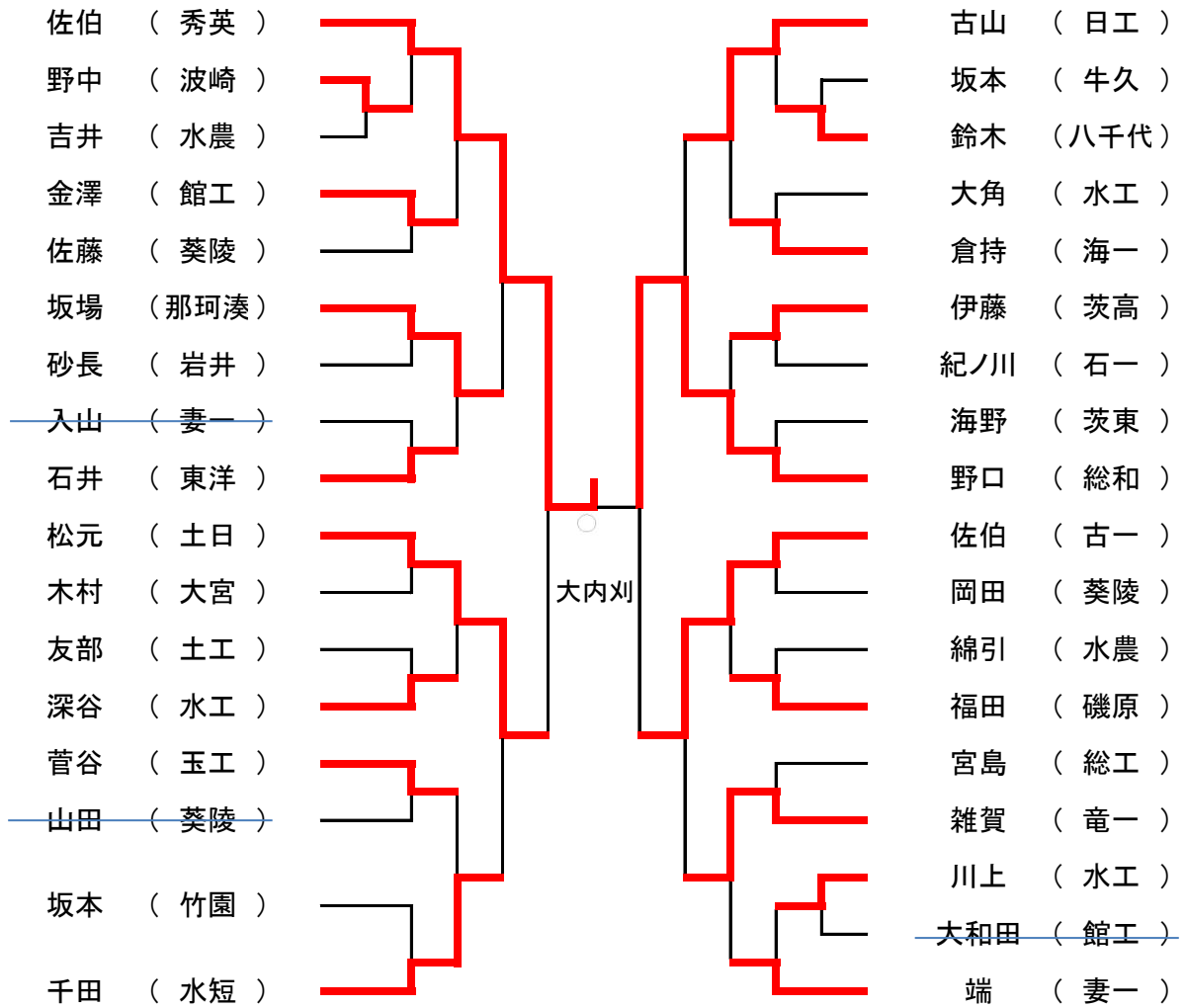

男子個人81kg級

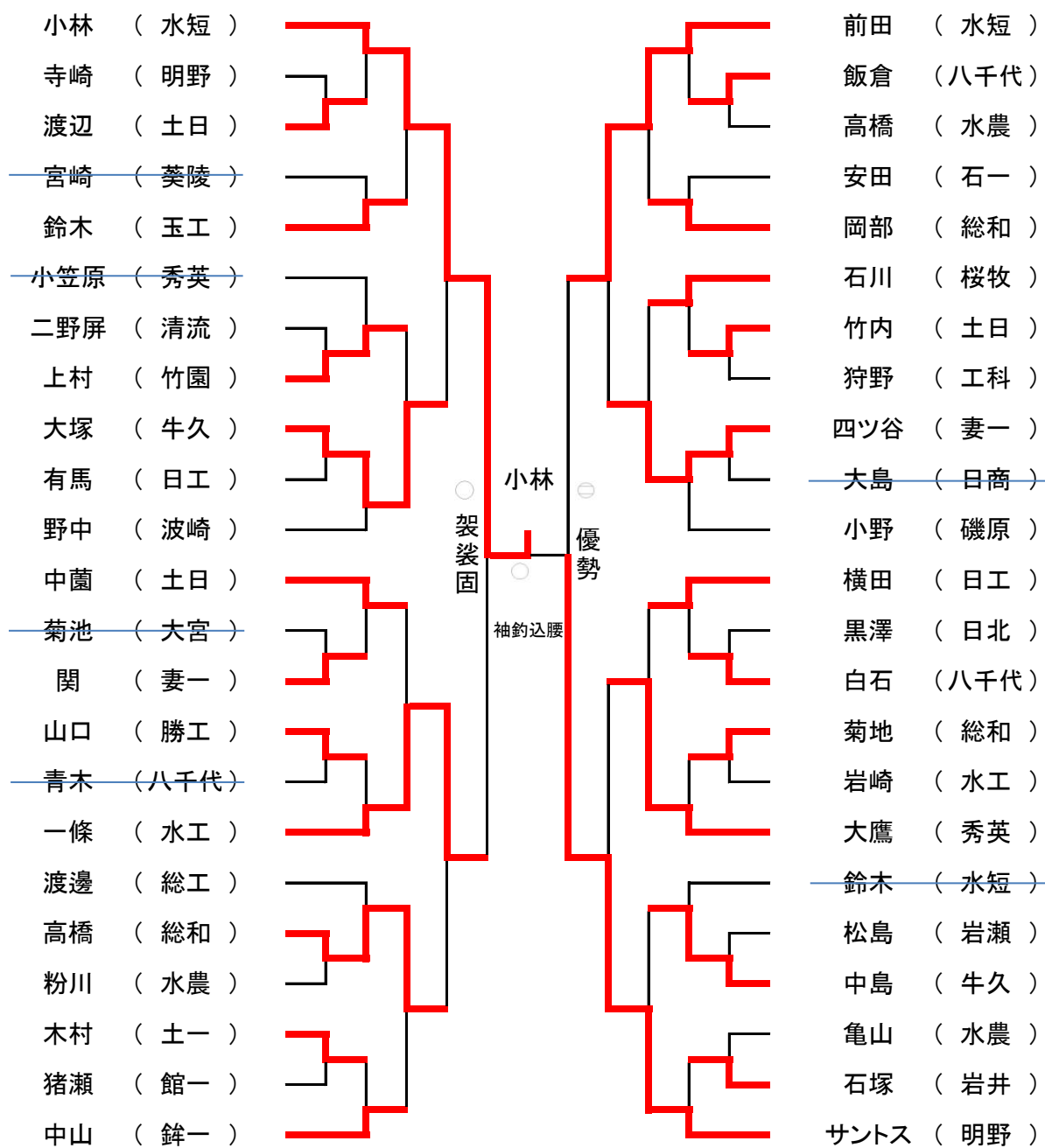

男子個人90kg級

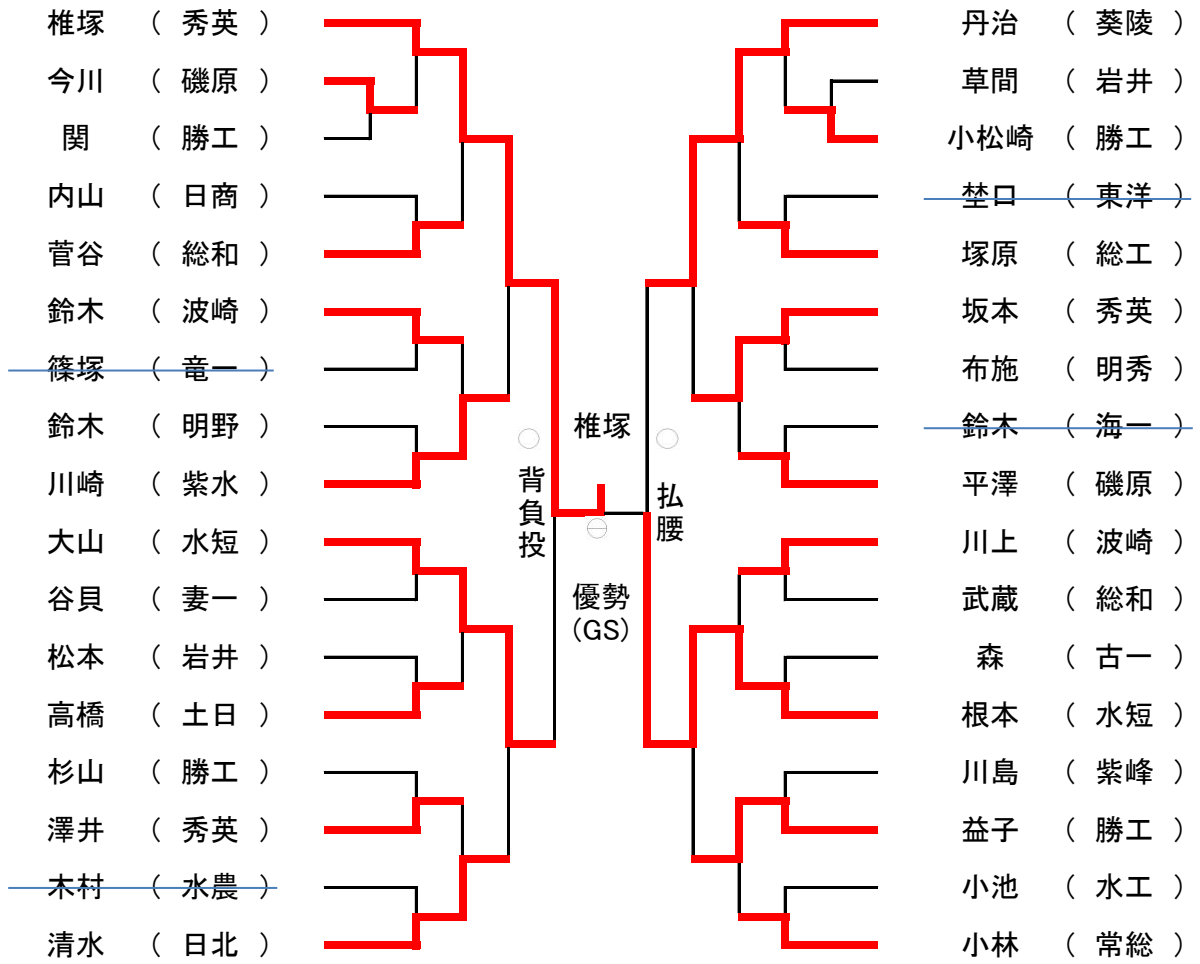

男子個人100kg級

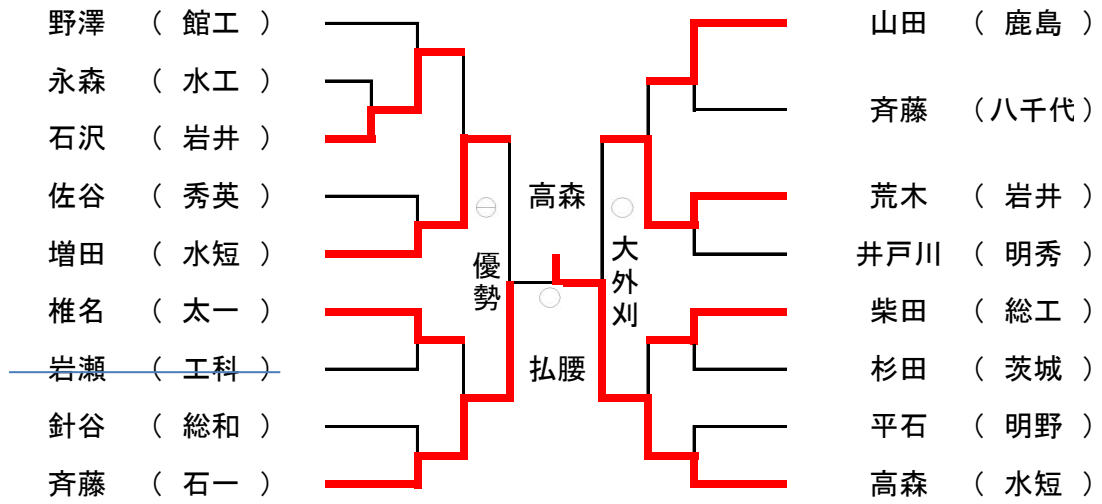



男子個人100kg超級

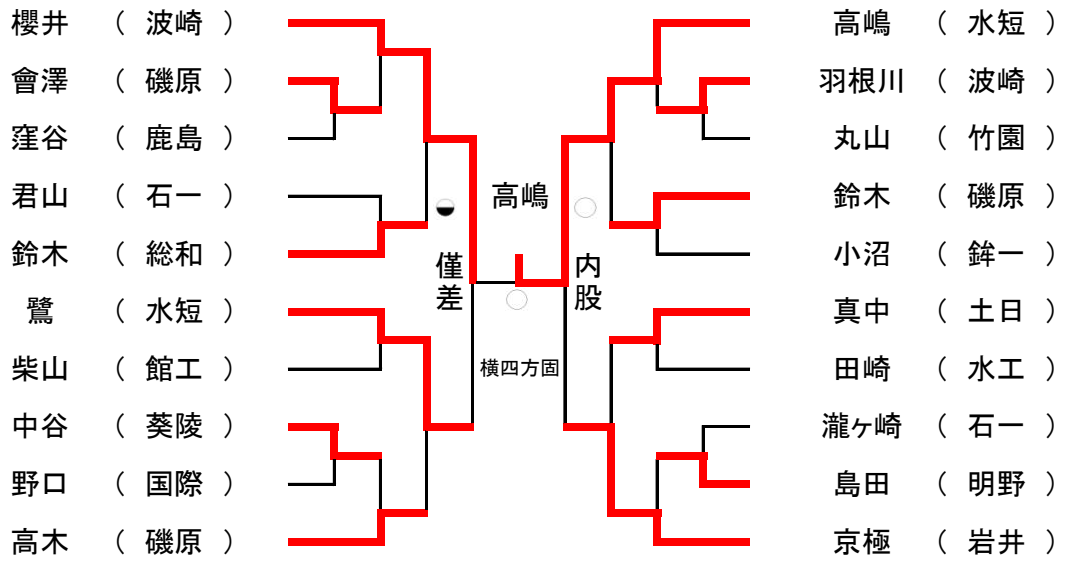

女子団体戦

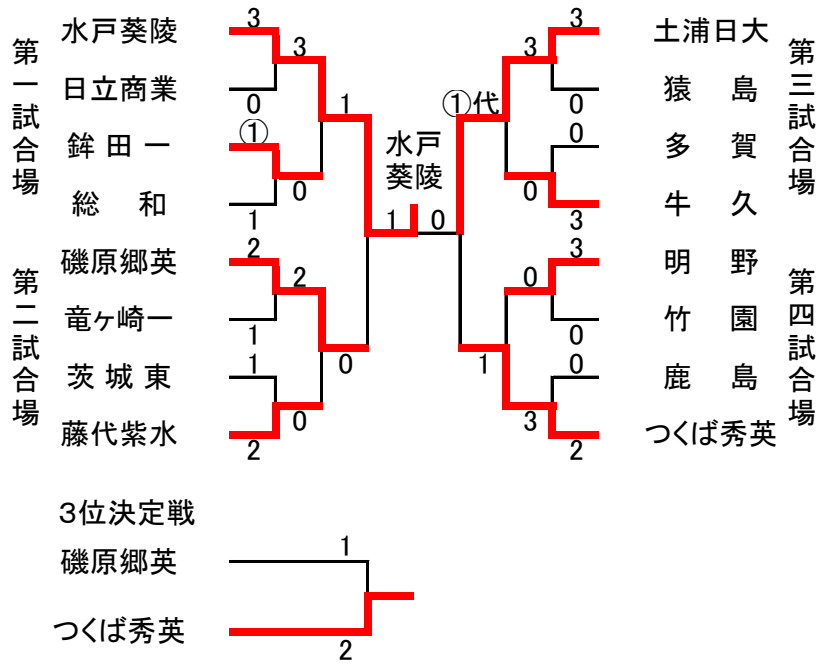

女子個人48kg級

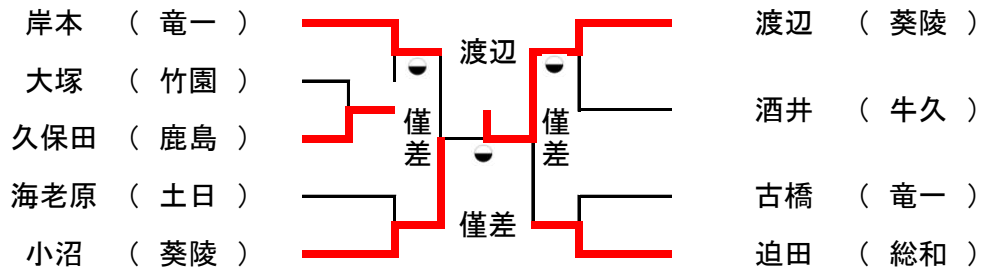

女子個人52kg級

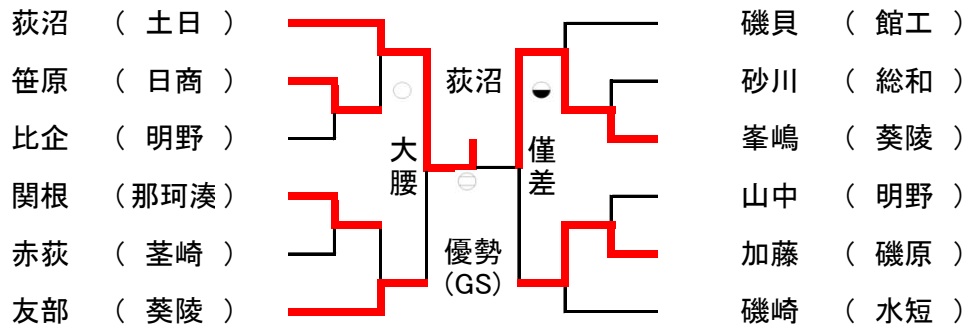

女子個人57kg級

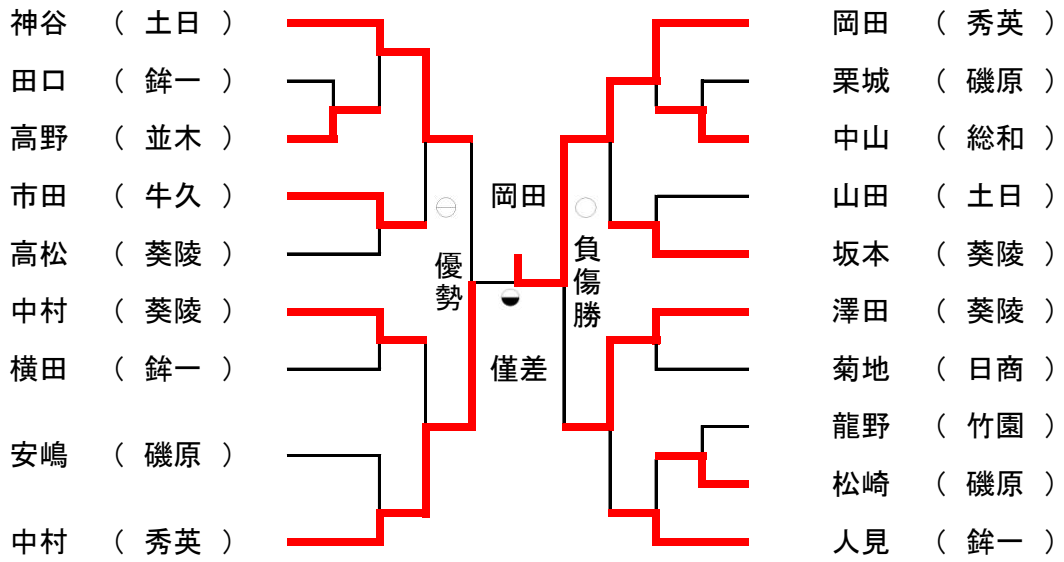

女子個人63kg級

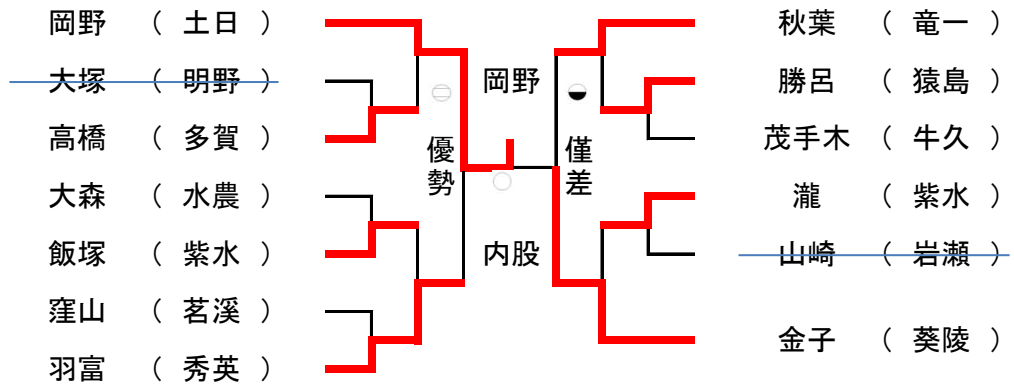

女子個人70kg級

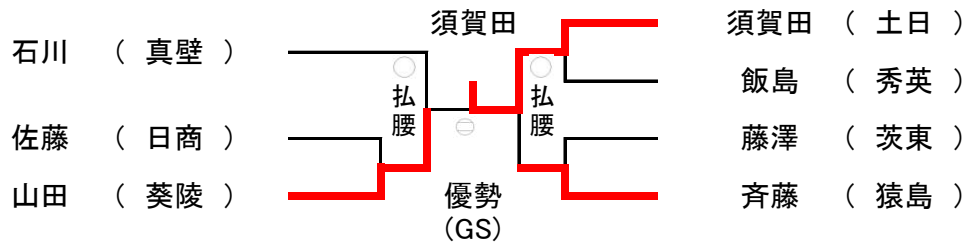

女子個人78kg級

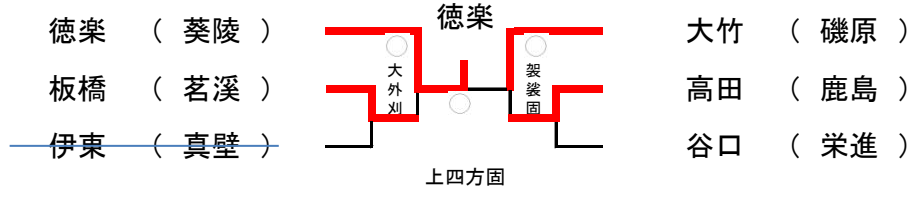



女子個人78kg超級

