

男子団体戦

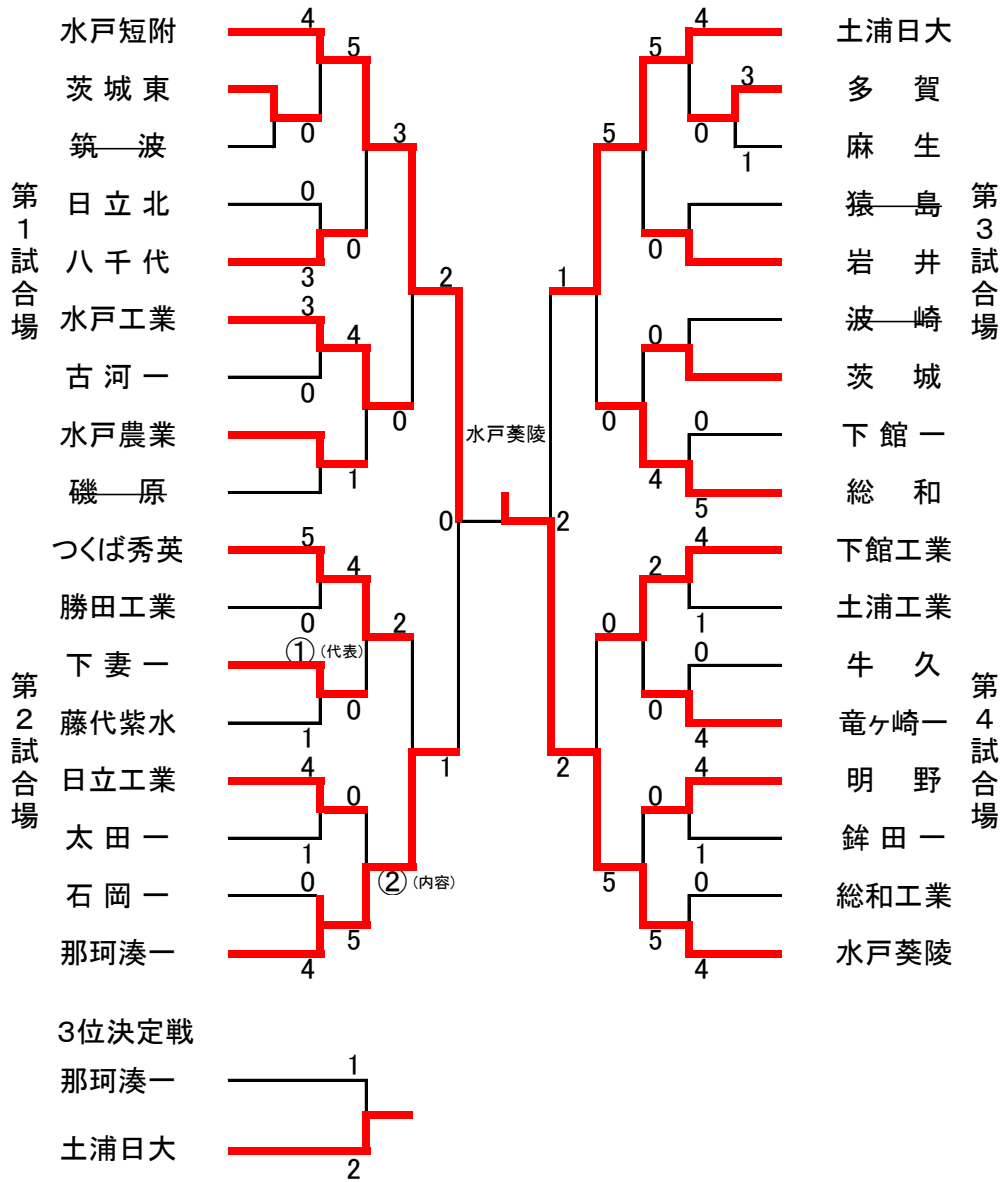

男子個人戦60kg級

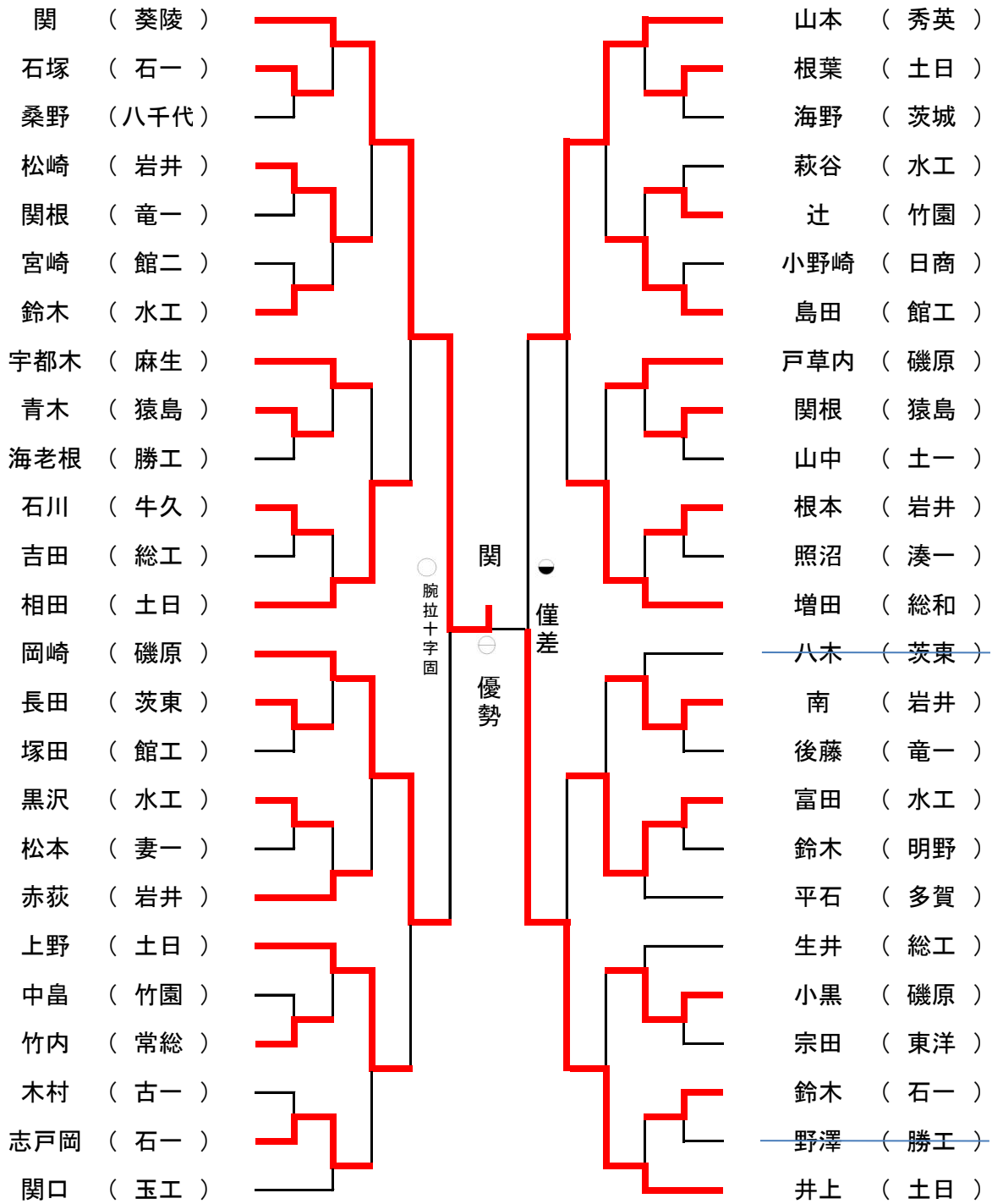

男子個人戦66kg級

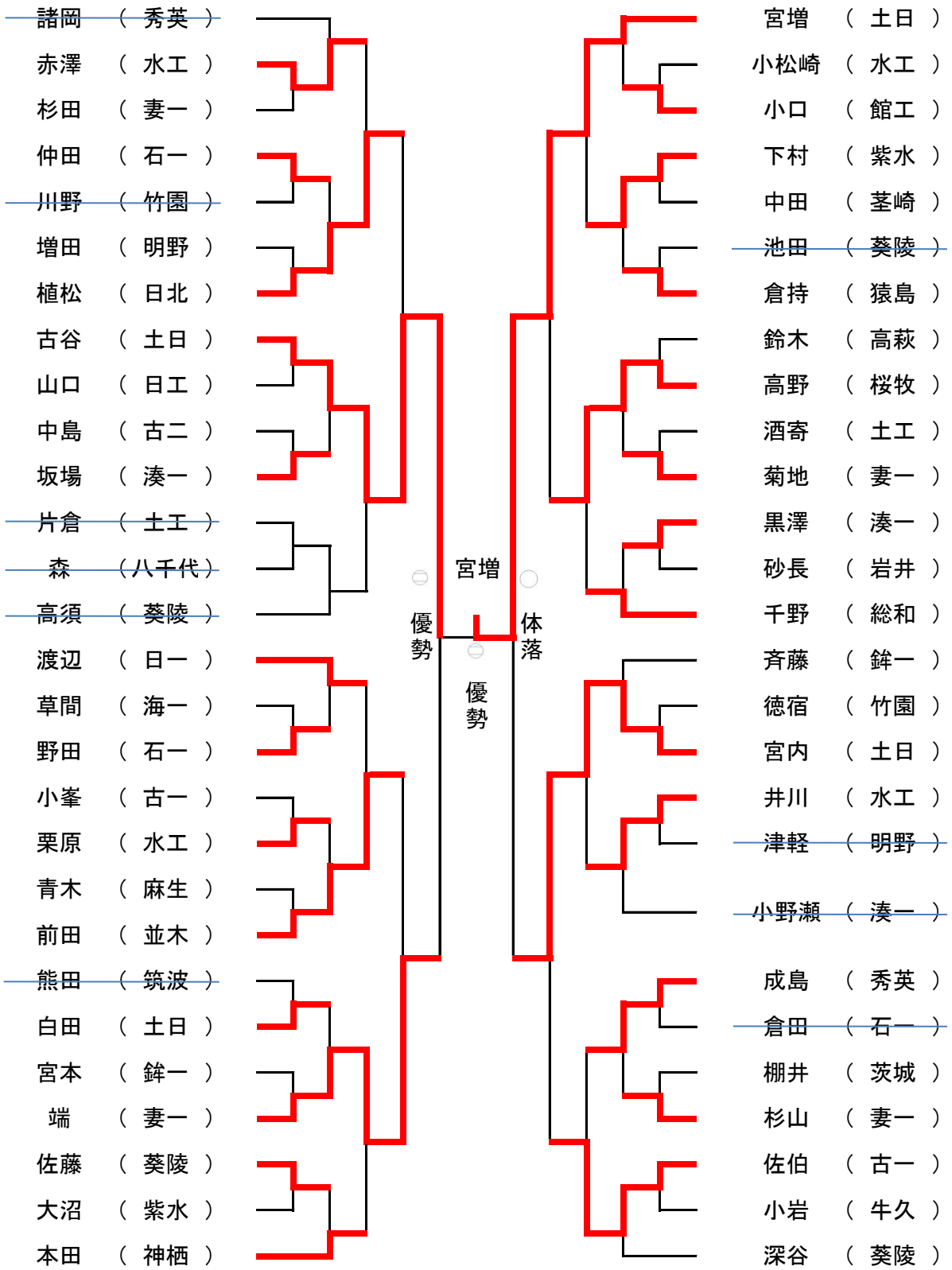

男子個人戦73kg級

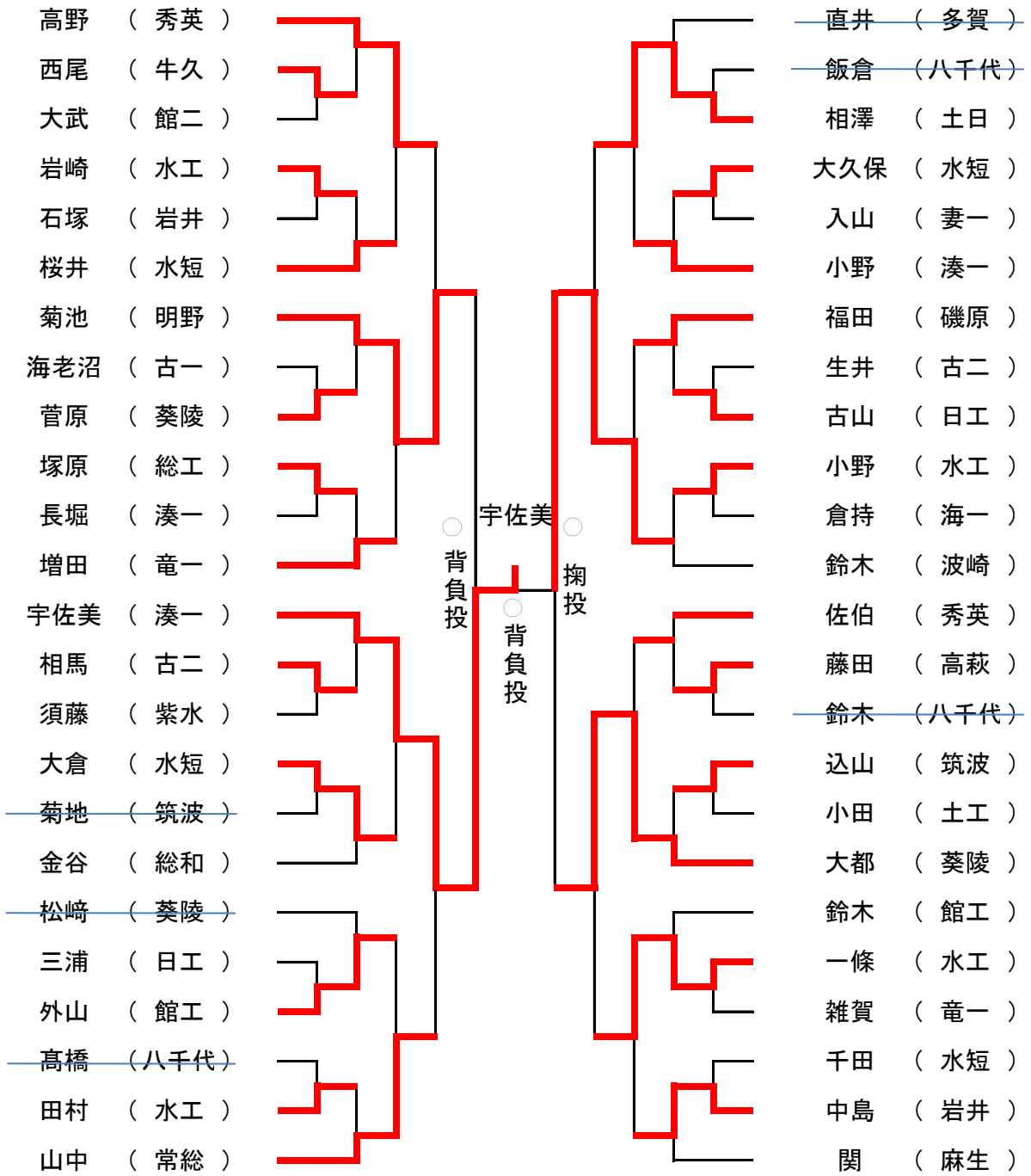

男子個人戦81kg級

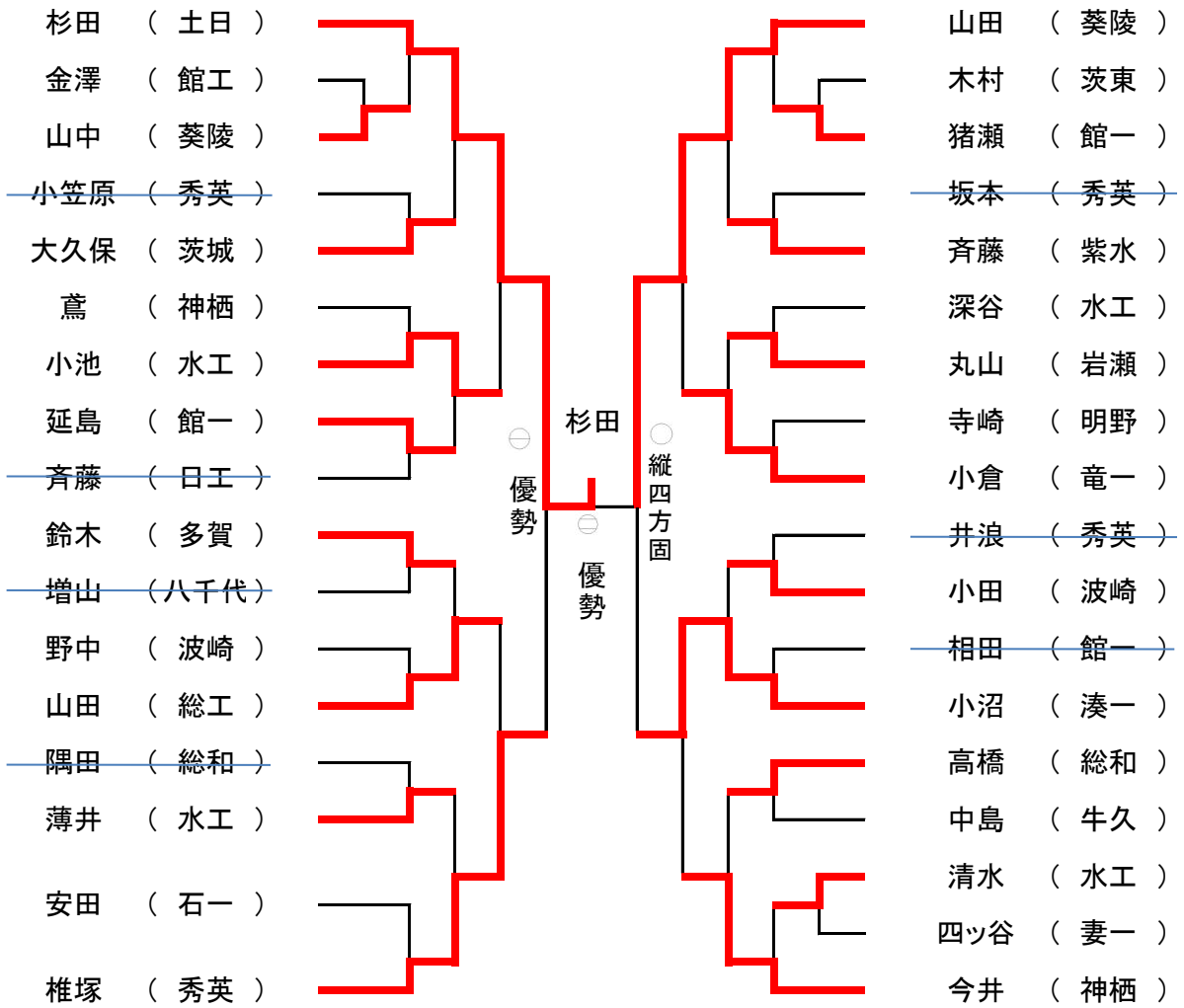

男子個人戦90kg級

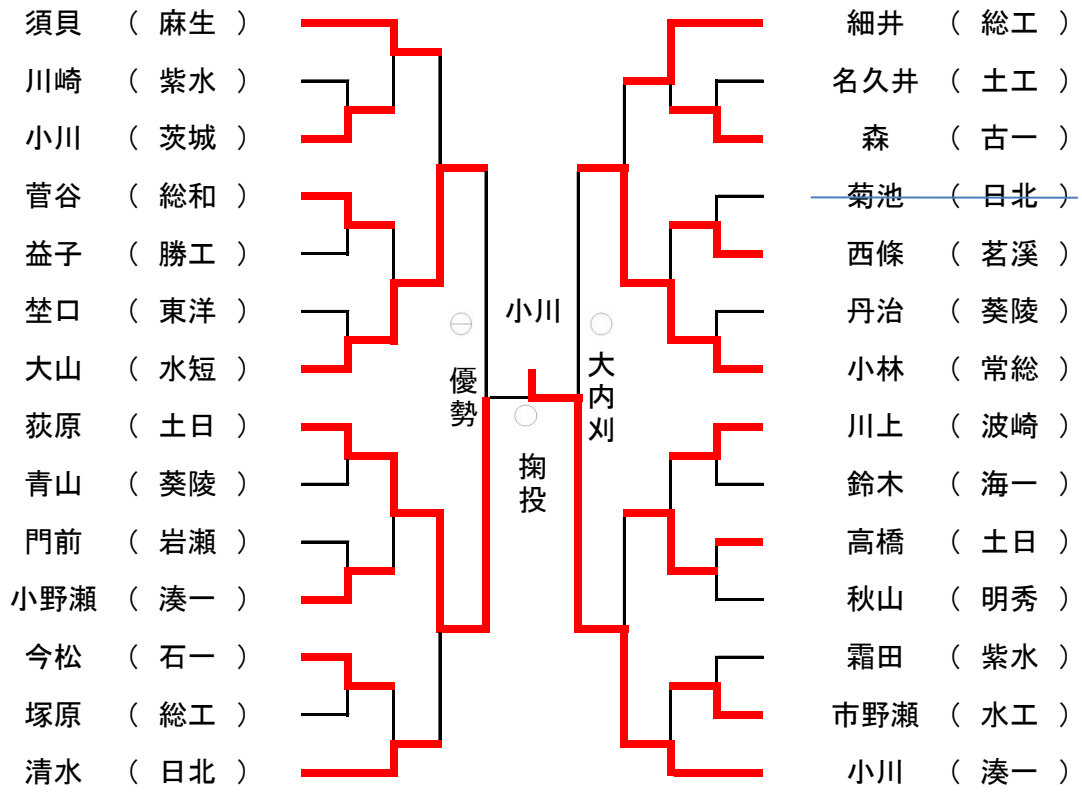

男子個人戦100kg級

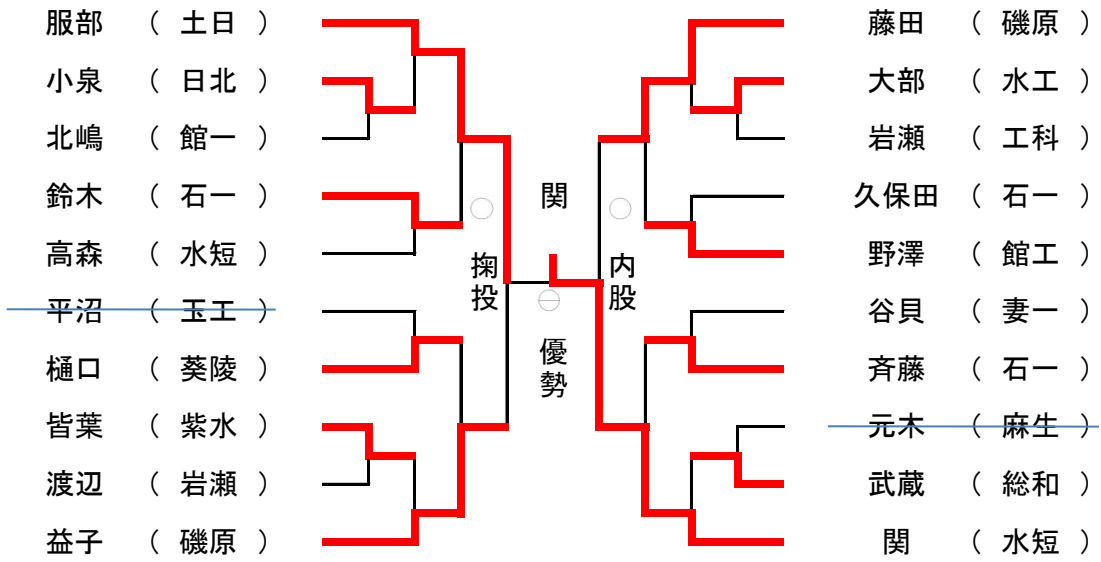

男子個人戦100kg超級

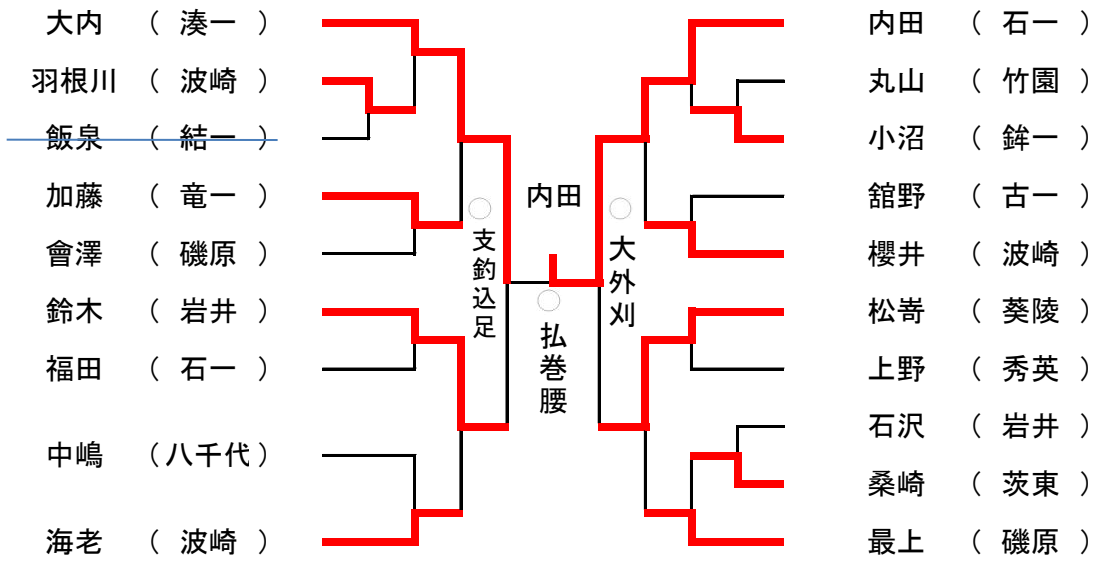



女子団体戦

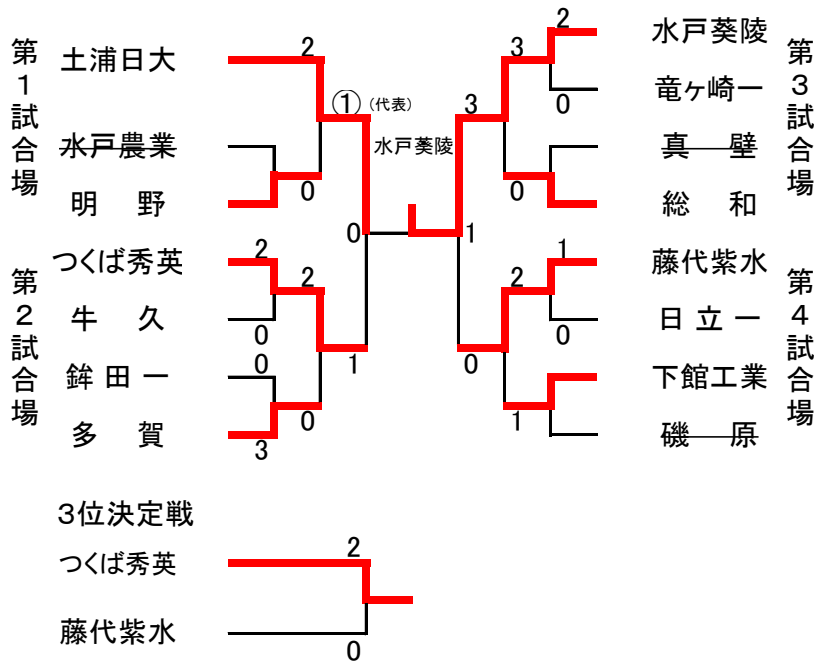

女子個人戦48kg級

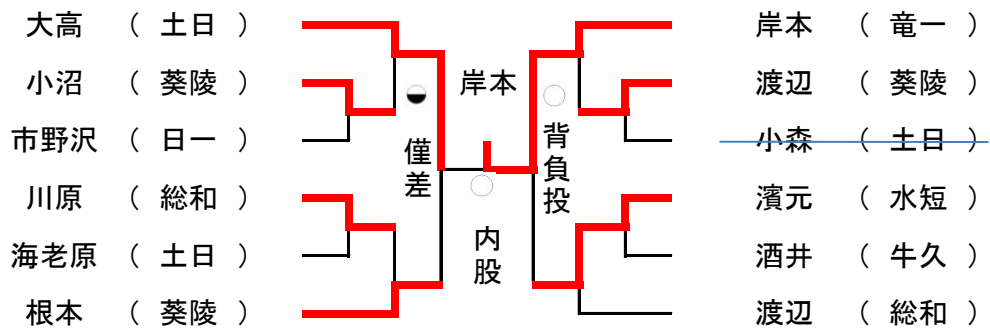

女子個人戦52kg級

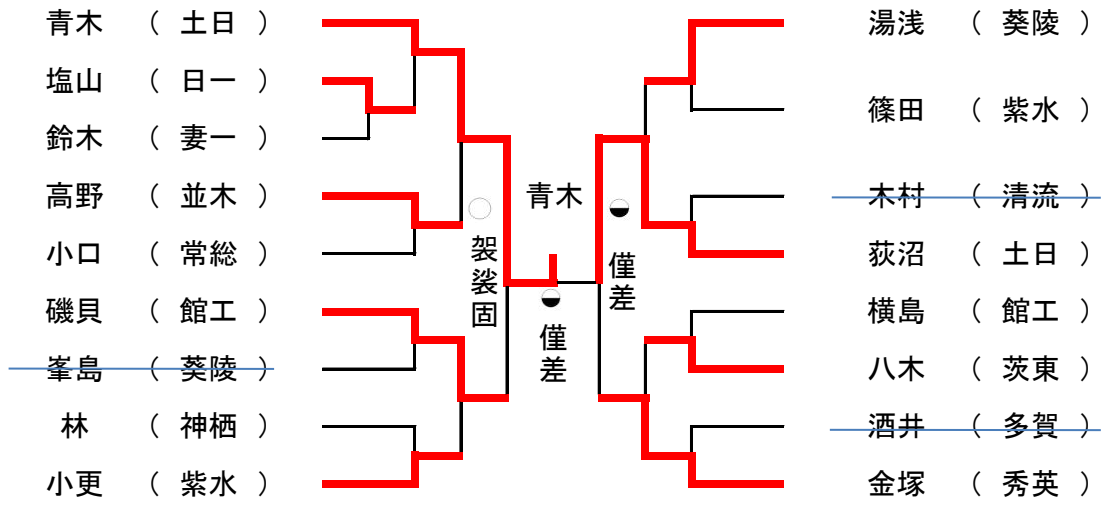

女子個人戦57kg級

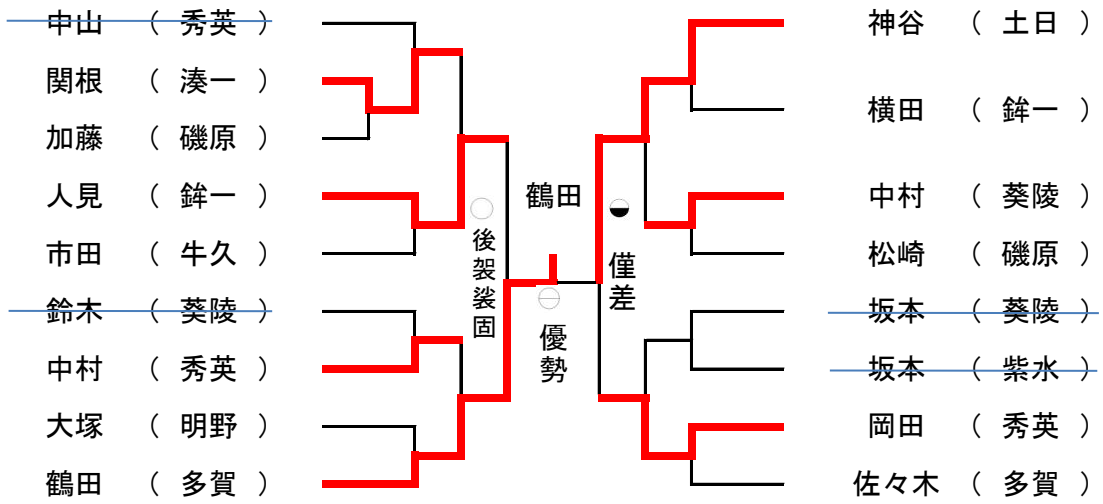

女子個人戦63kg級

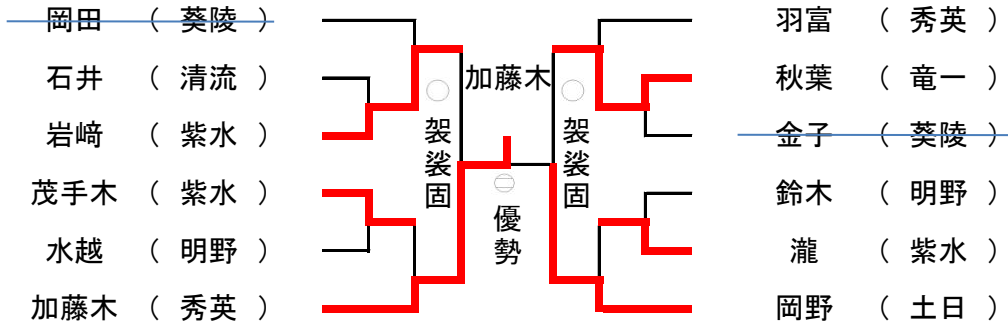

女子個人戦70kg級

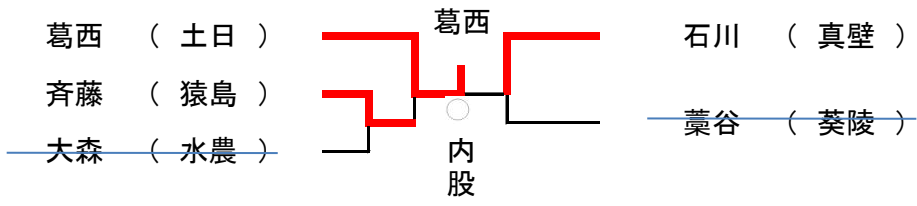

女子個人戦78kg級

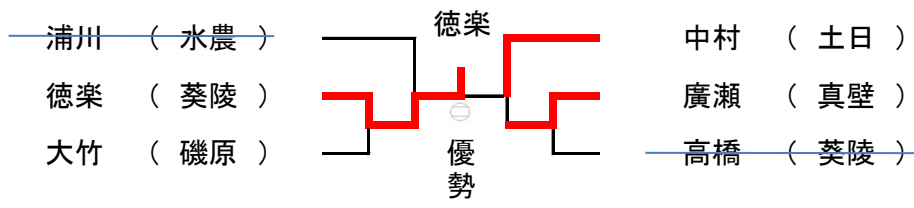

女子個人戦78kg超級

